



Our technology makes an impact.

**DOSING TECHNOLOGY**



## **BIOMIXER**

**Model 12/1M  
Model 16/1M  
Model 18/1M  
Model 20/1M  
Model 30/2M  
Model 35/2M  
Model 40/2M  
Model 50/3M  
Model 60/3M  
Model 80/3M**

# Areas of application

Optimal solutions for all requirements.

Our experience has taught us that every plant has its own unique requirements when it comes to capacity, substrate materials and conveyor technology. With our customized and proven biomixers,

we here at PUMPE have developed just the right solution to each of these challenges. Here are a few examples of areas of application.



## Biomixer model 16/1M

- 16 m<sup>3</sup> storage volume
- A vertical mixing screw
- Mixing screw drive 22 kW, optional 30 kW
- 3-piece conveyor screw section model 360, consists of base frame screw, conveyor screw and fermenter screw
- Weighing system



## Biomixer model 30/2M

- 30 m<sup>3</sup> storage volume
- Two vertical mixing screws
- Mixing screw drive 22 kW, optional 30 kW
- Out-feed with hydraulically operated slide feed
- Vertical fermenter screw model 600
- Weighing system



## Biomixer model 30/2M

- 30 m<sup>3</sup> storage volume
- Two vertical mixing screws
- Mixing screw drive 22 kW, optional 30 kW
- 2-piece conveyor screw section model 360, consists of base frame screw and vertical fermenter screw



Biomixer model 50/3M



Biomixer model 60/3M – Container constructed entirely with stainless steel



# Biomixer from PUMPE

Long-lasting. Reliable. Efficient.

The smooth supply of substrate to your biogas plant is of existential importance. Maximum yield can only be achieved when substrate is evenly and continuously dosed. With our PUMPE biomixers, you can be assured of a long-lasting system with proven technology, customizable options and of course our comprehensive PUMPE service package.



### Container (upper section)

The base frame can be constructed using either steel or stainless steel, as desired. Depending on the model, fill volumes vary between 12 and 80 cubic meters.



### Container (base)

Our base frame is made out of low-wear stainless steel for longevity and maximum stability.

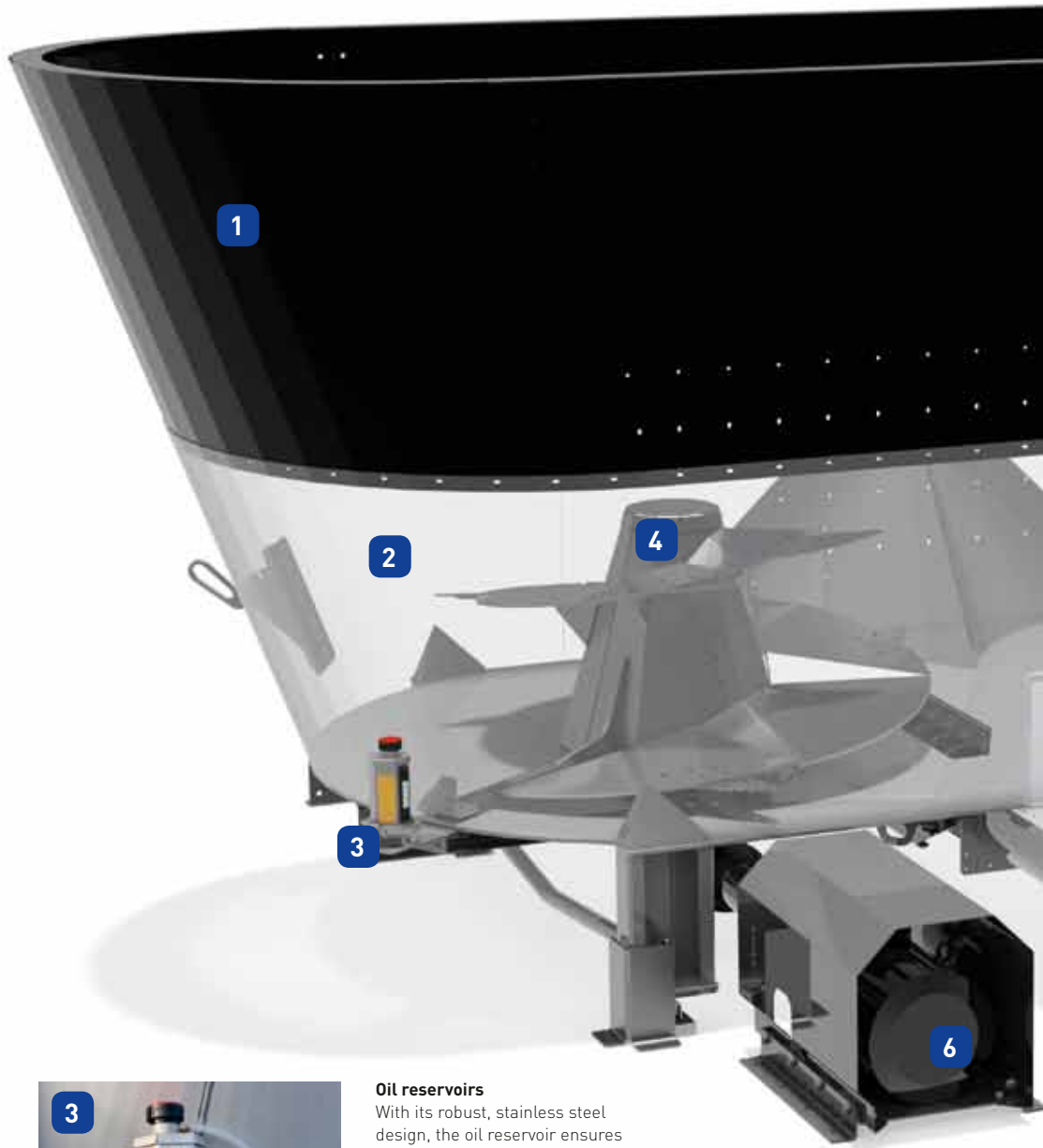

### Oil reservoirs

With its robust, stainless steel design, the oil reservoir ensures easy control of optimum levels in the planetary bevel gear. The gear's output bearing is supplied with lubricant and easy to use.

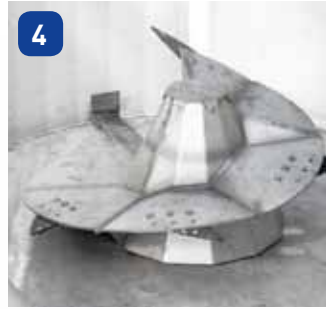

**Vertical mixing screw**

With a speed of 8-12 r/min, the mixing screws ensure needs-based processing of substrates and subsequently transfer them to the conveyance technology. Different vertical mixing screws are available according to material and container volume, in either steel or stainless steel. The speed can be controlled with a frequency converter.



**Mechanical shear bar**

The individually adjustable shear bars interrupt, when necessary, substrate rotation, thus supporting the optimal mixing of contents.

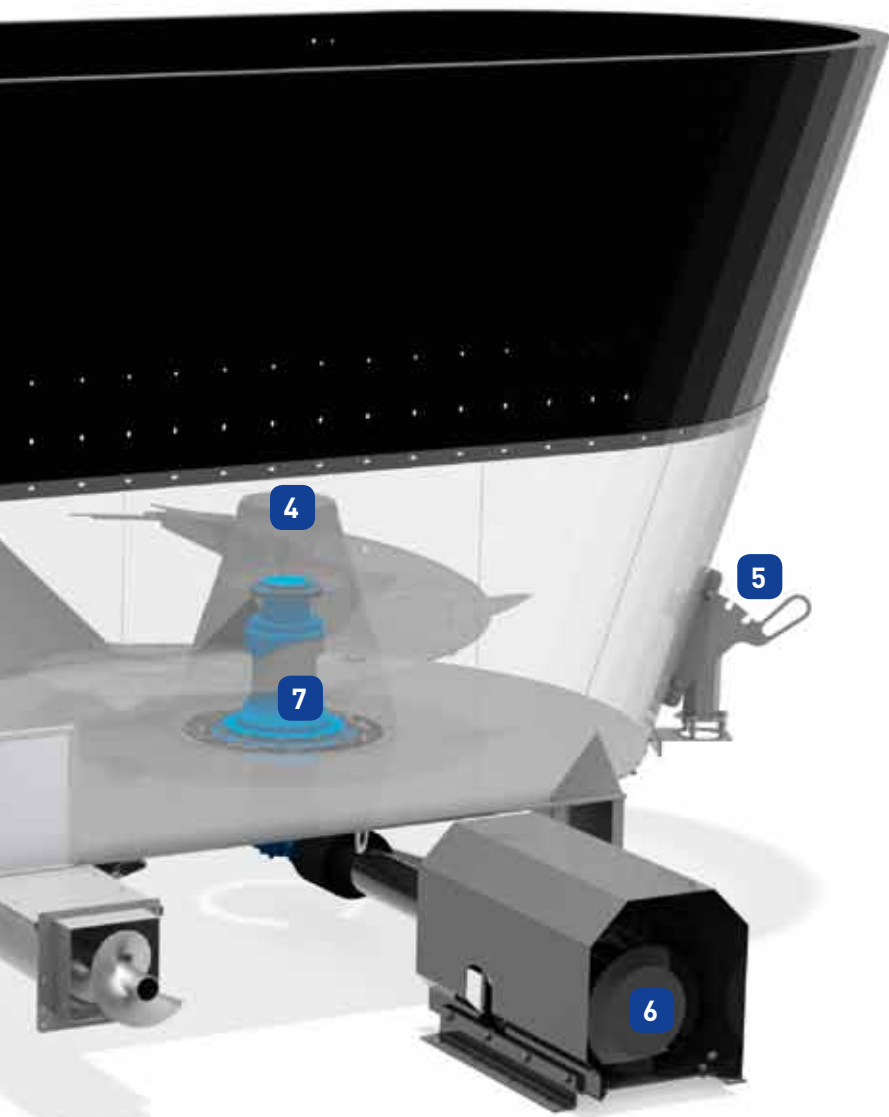

**Electric drives**

Robust electric motors (equipped with a spur gear system depending on the application) transfer the output to a planetary bevel gear via a drive shaft. The drives are available in performance classes 22, 30 and 45 kW.



**Planetary bevel gear**

This type of gear mechanism transmits high torques with a compact design by distributing the load across multiple planetary gears. The result is the highest degree of efficiency, productivity and process reliability.

# Equipment options and accessories

Customized biomixers for your business.



### Cover

In order to reduce emissions and weathering, the biomixers can be equipped with a hydraulically operated cover, which consists of a stainless steel frame covered with a UV-resistant tarp. The cover can be operated via radio remote control upon request.



### Overload protection

In order to prevent substrate from getting behind the container during loading, additional stainless steel assembly elements can be mounted (only possible for devices without covers).



### Weighing system

For precise control of fill quantities, we rely on shear force or pressure sensors. Various display devices – optionally coupled with an easily legible, alphanumeric large display with two rows of LEDs – ensure ease of use and simple programming of optimum dosage. For further processing of data, analogue signal outputs as well as Profibus interfaces can be made available.



### Out-feed with feeder gate

Our devices can be equipped with a front-mounted outlet valve, which can be controlled manually or hydraulically.



### Access opening

In order to simplify maintenance, we offer optional access openings in the sidewalls of the containers.



### Ladder

A hot-dip galvanized, non-slip ladder is available for a good and above all safe view of the mixing container.



### Controls

We provide custom-made control devices for controlling the dosing unit. In conjunction with the corresponding weighing computer, the dosing unit can also be independently operated.

# An overview of models

## Technology that makes an impact.

Choosing the optimal biomixer is based on individual requirements such as the size of the plant, the spatial conditions, the type of substrates, their mixing ratios and the feeding intervals. In order to meet the individual needs of our clients, we offer ten different

model sizes with various motorization and equipment options. Upon request, each plant can be supplied with a weighing device and complete electrical controls. We offer a customized solution for agriculturalists and energy producers.

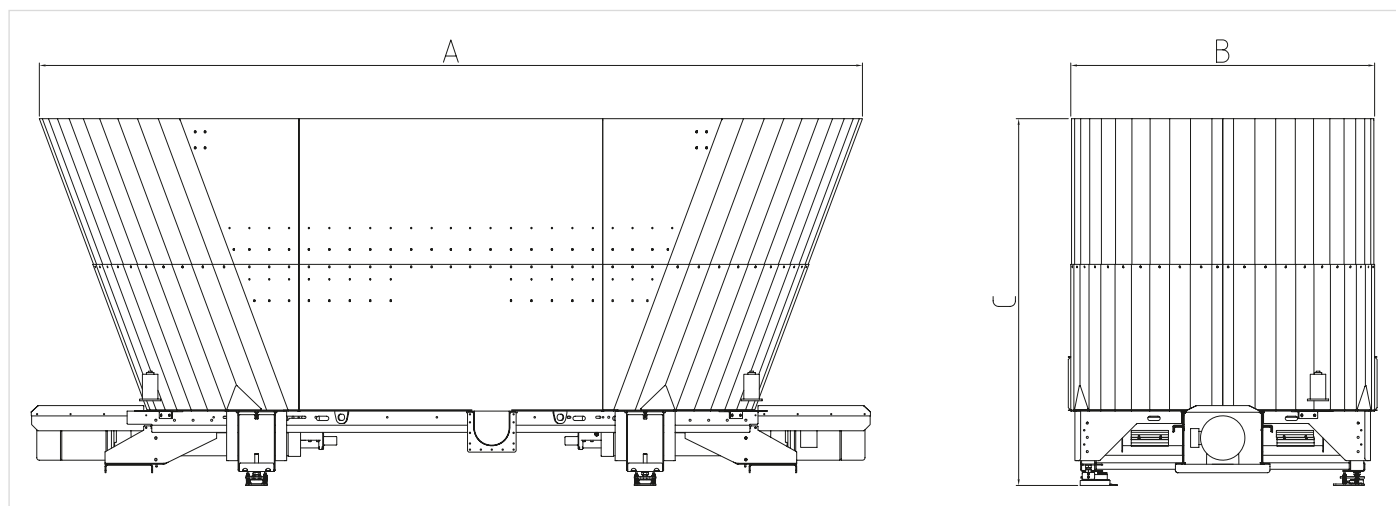

Model	Standard model								Robust model	
	12/1M	16/1M	18/1M	20/1M	30/2M	35/2M	40/2M	50/3M	60/3M	80/3M
contents (m <sup>3</sup> )	12	16	18	20	30	35	40	50	60	80
A – container length (m)	3.92	4.20	4.20	4.20	6.65	6.65	6.65	9.10	8.60	8.60
B – container width (m)	2.45	2.45	2.45	2.45	2.45	2.45	2.45	2.45	2.95	2.95
C – overall height (m)	2.60	2.95	3.20	3.40	2.95	3.35	3.70	3.95	3.70	4.40
drive	1	1	1	1	2	2	2	3	3	3
max. load (t)	6	8	9	10	15	17.5	20	25	45	45
recommended drive (kW)	22	22	22	30	22	30	30	22	30	45
optional drive (kW)	15	30	30	22	30	22	22	30	45	30
mixing blade stainless steel	o	o	o	o	o	o	o	o	o	o
cutter stainless steel	o	o	o	o	o	o	o	o	o	o
2 hinged shear bars	o	o	o	o	o	o	o	o	o	o
ladder	o	o	o	o	o	o	o	o	o	o
hinged cover	o	o	o	o	o	o	o	o	o	o
base frame stainless steel	x	x	x	x	x	x	x	x	x	x
container top stainless steel	o	o	o	o	o	o	o	o	o	o
overload protection stainless steel	o	o	o	o	o	o	o	o	o	o
weighing system	o	o	o	o	o	o	o	o	o	o
electric controls	o	o	o	o	o	o	o	o	o	o
transfer to screw model 360	x	x	x	x	x	x	x	x	x	x
transfer to screw model 450	o	o	o	o	o	o	o	o	o	o

x = standard equipment, o = optional scope of supply

# Konrad Pumpe GmbH

Innovative technology plus experience.



**AGRICULTURAL TECHNOLOGY**

For more than 180 years, we have been closely following the developments and increasing demands of the agricultural industry. Our barn equipment and feeding systems are characterized by sophisticated functionality, individual concepts and the highest standards of quality and durability. Partnership is our foundation; reliability and professionalism are our recipe for success.



**DOSING TECHNOLOGY**

The transition to renewable sources of energy is opening up new perspectives for agricultural practices. We here at PUMPE are reliable partners to the energy farmers of tomorrow and offer innovative products and proven technology for biogas operators. From the design process, to manufacturing in our own production facilities, to installation and maintenance, we guarantee perfect service from a single source.



**METAL TECHNOLOGY**

Our origin is our expertise. Since 1830, we have been forging solid realities out of metal. With the latest technology and our years of experience, we are coming up with customized metal solutions for various applications in agriculture and industry. Custom-made solutions and in-house developments using steel and stainless steel is our passion.

## Our service for your success

- Full service – from design and manufacturing to installation and service
- 365 days a year customer service for our clients
- Our own high bay warehouse and in-house production guarantee availability of all spare parts
- Quick reaction times and personal contacts
- Customized production and adaptations for individual specifications
- Close cooperation with our clients and consulting by our specialists
- Short distances and clear structures for perfect customer service
- Worldwide installation and maintenance of your equipment
- Quality and material "Made in Germany"
- A qualified staff that receives ongoing training guarantees the highest level of service
- More than 180 years of experience in the metal processing
- Owner-managed family company



### Konrad Pumpe GmbH

- project engineering
- special machinery
- CNC sheet metal
- accessory and containers
- machinery and equipment
- steel construction
- barn equipment
- feeding systems for pigs
- dosing technology for biogas plants



**Konrad Pumpe GmbH**  
Schörmelweg 24 | 48324 Sendenhorst | Germany  
Phone +49 2526 93290 | Fax +49 2526 932925  
[www.pumpegmbh.de](http://www.pumpegmbh.de)



**Danmark**  
Lobe ApS  
Tlf. +45 7684 3484  
Mail: [sales@lobe.dk](mailto:sales@lobe.dk)  
[www.lobe.dk](http://www.lobe.dk)

**Norge**  
Lobe AS  
Tlf. +47 6710 5000  
Mail: [sales@lobe.no](mailto:sales@lobe.no)  
[www.lobe.no](http://www.lobe.no)