

B-MX
SUBMERSIBLE
MIXER



B-MX SUBMERSIBLE MIXER

MORE EFFECTIVE AGITATION

The B-MX submersible mixer ensures that liquid media with solids are mixed reliably and effectively.

Agitation prevents the formation of floating and sinking layers and the homogeneous stored liquid is prepared optimally for spreading or separation.

The B-MX works very efficiently. The smooth & streamlined design of the mixer allows liquid to flow to the displacement blades without creating turbulence. This ensures excellent agitation results with minimum energy input. The high-precision casing and all wetted parts are made of high-grade stainless steel.

B-MX	Output in [kW]	Output in [m ³ /h]	Rotational speed in [UpM]	Weight in [kg]
B-MX 9	9	3,780	346	170
B-MX 13	13	5,020	346	180
B-MX 18	18	6,860	346	220
B-MX 22	22	8,640	346	240

CONSTRUCTION AND FUNCTION

1 The agitator body

The submersible mixer has an aerodynamic design. The liquid flows to the displacement blades without turbulence. This allows optimal use of the supplied energy.

2 The agitator blade

Usually, the agitator blade of the B-MX consists of two rotor blades which are designed in such a way that their rotation produces maximum thrust.

3 The guide carriage

The submersible mixer is connected to the guide rail means of the guide carriage. The inclination angle can be flexibly adjusted thanks to the installation of the mixer on alternative mounting holes and thus can be perfectly adapted to the conditions on site. This way, optimum agitation results are guaranteed.

4 The cable duct

The three-phase drive is supplied with power through the permanently enclosed yet replaceable cable duct. To replace the cable only a maintenance flap [6] must be opened. The mixer does not have to be removed.

5 Mechanical seal and intermediate chamber

The system is sealed by a high-quality mechanical seal. A high-volume quench chamber ensures the highest degree of operational safety.

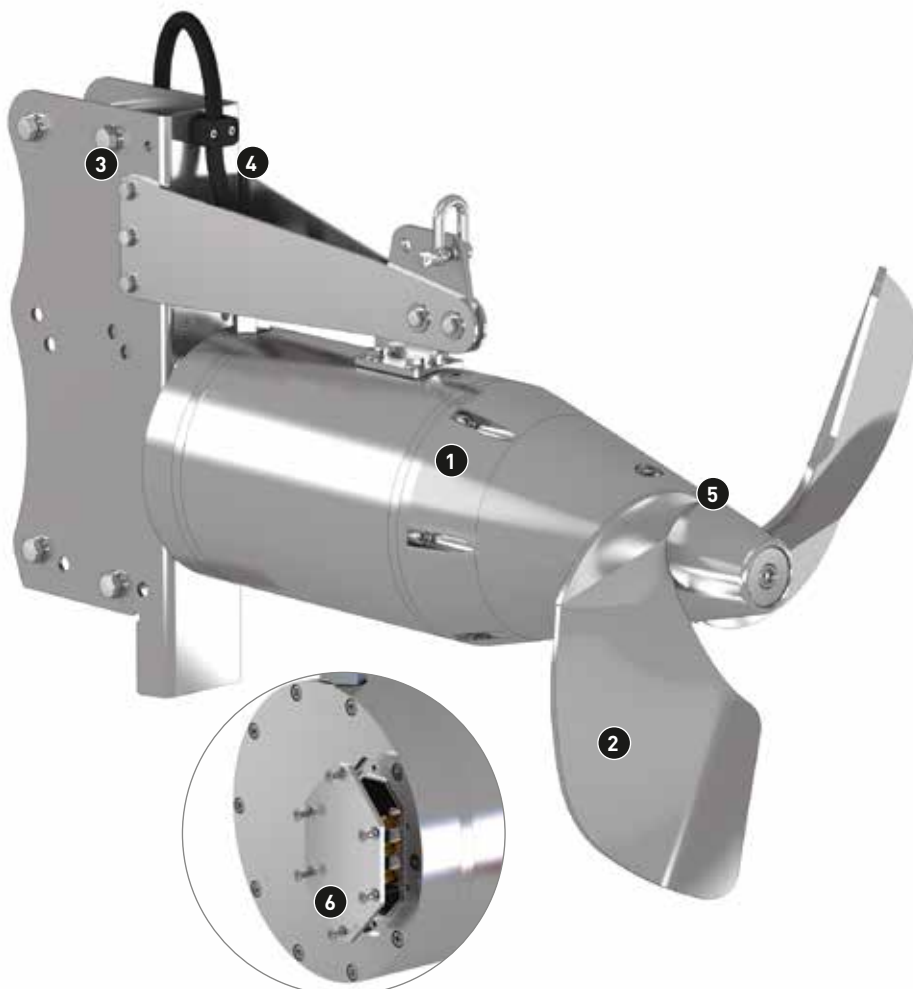

B-MX AT A GLANCE

- + different sizes can be selected for an optimum cost-benefit-ratio
- + aerodynamic design guarantees optimum agitation results at lowest energy costs (high efficiency)
- + low-maintenance design facilitates time- and cost-saving repairs
- + completely made of stainless steel for a long service life

VERSATILE USE

- Liquid manure
- Treatment of digested sludge
- Primary waste water treatment
- Secondary waste water treatment
- Homogenization basins
- Pumping stations
- Nitrification plants
- Rainwater retention basins
- Sludge collectors
- Biogas substrate
- etc

AERODYNAMIC

The slim design of the B-MX and the geometry of the agitator blades have been optimized by means of the latest flow simulation programs and ensure lowest energy input at maximum efficiency.

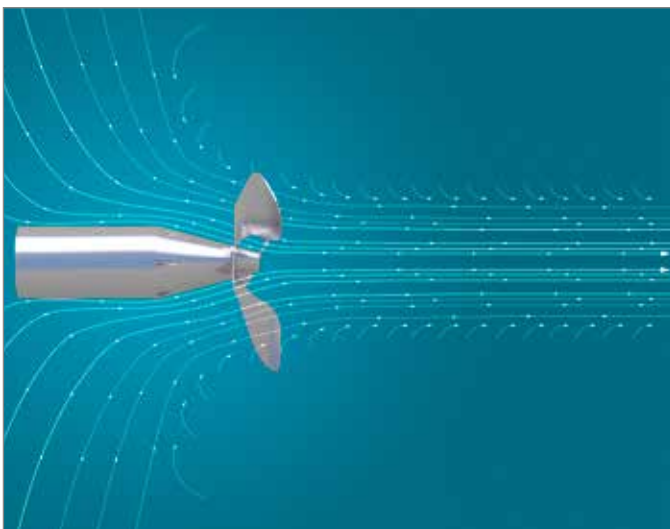

DIMENSIONS

The B-MX submersible mixer is very compact and powerful and can be retrofitted into existing systems with ease.

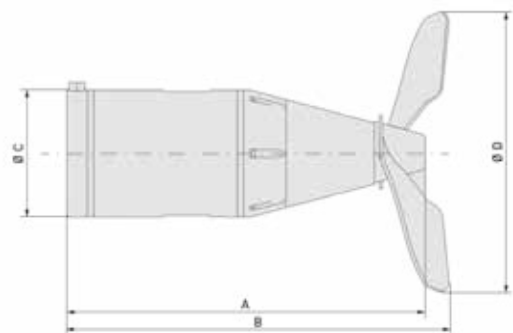

B-MX [kW]	A [mm]	B [mm]	C [mm]	D [mm]
B-MX 9	770	840	273	650
B-MX 13	770	840	273	650
B-MX 18	895	965	273	750
B-MX 22	895	965	273	750

EASY HANDLING MIXER ON GUIDE PIPE

The B-MX **[1]** is connected to the guide rail **[3]** by means of the guide carriage **[2]**. The guide pipe guides the mixer. Attaching the mixer to the container wall **[4]** is not necessary.

The adjustment unit **[5]** can be used to change the height and the lateral position of the mixer. The B-MX can always be adjusted optimally with changing fill levels, thus ensuring the best possible homogenization of your stored liquid. The working platform **[6]** provides easy access to the adjustment unit. From here, you can look into the tank. On request, we manufacture the working platform exactly to your specification.

EASILY SWIVELED AND ADJUSTED IN HEIGHT

After the lock **(a)** has been released, the B-MX can be swiveled into the desired position using the swivel lever **(b)**. The cable winch **(c)** made of stainless steel can be used to change the height of the B-MX guided by a guide pipe – simple and effective.

The cable winch is equipped with an integrated brake which prevents the B-MX from changing its position accidentally.



The bearing fixed to the tank bottom ensures a secure, firm stand.



STAINLESS STEEL TANKS FOR STORING LIQUIDS

Börger stainless steel tanks available in different materials grades are suitable for storing any liquid.

Capacities between 30 to 5,000 m³, various accessories and roof constructions allow a customized, customer centered solution. The storage size can be increased without problems due to the segmented tank design.

STAINLESS STEEL TANK AT A GLANCE

- + Capacity of 30 to 5,000 m³
- + Maintenance-free and lasting value
- + Can be increased and disassembled
- + Different roof constructions
- + Versatile function



BÖRGER®

EXCELLENCE – MADE TO LAST



Börgen GmbH
Borken-Weseke, Germany
Phone +49 2862 9103-0
info@boerger.de

Börgen Benelux
Ootmarsum, Netherlands
info@boerger-pumps.nl

Boerger LLC
Chanhassen, MN, USA
america@boerger.com

Börgen France Sarl
Wittersheim, France
info@borger.fr

Boerger Polska Sp. z o.o.
Gliwice, Poland
info@boerger.pl

Börgen UK Ltd.
Staffordshire, United Kingdom
uk@boerger.com

Boerger Pumps Asia Pte Ltd
Singapore
asia@boerger.com

Boerger Pumps Asia Pte Ltd
Gurugram, Haryana, India
india@boerger.com

Boerger Pumps (Shanghai) Co., Ltd.
Pudong, Shanghai, China
shanghai@boerger.com

000 Börgen Pumps
Moscow, Russia
russia@boerger.com

www.boerger.com