

PUMP SOLUTIONS
FOR ENVIRONMENTAL
AND MUNICIPAL
TECHNOLOGY



YOU CAN RELY ON THEM: BÖRGER ROTARY LOBE PUMPS



Market leader for elastomer-coated rotary lobe pumps and experts in macerating technology. We are represented in more than 65 countries and remain on course for growth. Not only are we a global player but also an independent, family-owned and second generation managed company.

“Constantly making things better” has been our guiding principle right from the start. This is evident by the quality, durability and ease of maintenance of all our products. Not only has it shaped our company history since 1975 with continuous new developments and innovations, it also is expressed in the honest and reliable partnership with customers, suppliers and staff.

Our pump solutions for environmental and municipal technology are customized to the specific demand. Whether pumping municipal waste water and biosolids, disposal of chemicals or for sewer rehabilitation – our experienced experts know the requirements, recommend suitable products or develop individual solutions for you. Highest quality “Made in Germany”.



BÖRGER®

EXCELLENCE – MADE TO LAST

Börrger rotary lobe pumps and macerators are designed for trouble free, continuous operation, as we want you to be able to work as effectively as possible. This is the reason why we only offer powerful and durable machines with unbeatable ease of maintenance features.

BÖRGER FIGURES

Foundation year.....1975

Family owned company.....
.....2nd generation

Headquarters.....
46325 Borken-Weseke, Germany,
with a large research and develop-
ment center, a CNC supported pro-
duction including manufacturing
halls with a total size of 15,000 m²

Number of employees.....
.....(as in February 2016)
.....200 in Germany
.....310 worldwide...

Locations worldwide.....9
international subsidiaries and many
sales offices in more than 65 countries

PERFECTLY MATCHED: BÖRGER PUMP AND MACERATING SYSTEMS

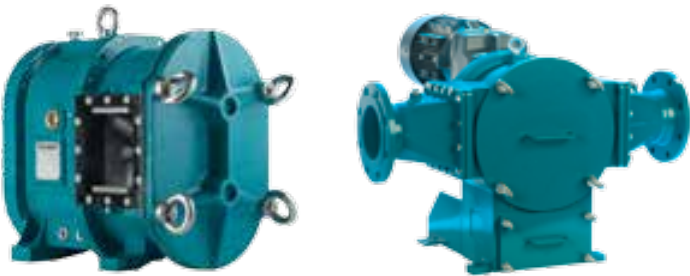

Whether waste water treatment plant, service provider for recycling and composting or operators of environmental technology systems – with the innovative and customized Börger pump solutions, we cover all applications in the area of environmental and municipal technology.

Due to the wide spectrum of rotor geometries, materials and pump sizes, we are perfectly suited for a variety of applications with different fluid types, wide flow ranges and local operating conditions. There is a reason the “Börger Pump” has become a synonym for flexibility in the rotary lobe pump industry.

RELIABLE AND EFFICIENT PROCESS

Börger pumps and macerators offer high performance with low space requirements and minimum energy consumption. Their reliability and durability guarantee market leading system safety to give you peace of mind.





RECYCLING

COLLECTION SYSTEM

WASTE WATER

GRAY WATER

PROCESS WATER

WASTE ACTIVATED SLUDGE

DEWATERED SLUDGE

FOOD WASTE

FLOTATION SLUDGE

SLURRIES

THICKENED SLUDGE

WASTE OIL / SOLVENTS

PRIMARY SLUDGE

SEWER FLUSHING

TUNNEL INGRESS

WELLPOINT DEWATERING

COLLECTION SYSTEM

PRODUCT OVERVIEW

ENVIRONMENTAL AND MUNICIPAL TECHNOLOGY

You can rely on Börger products: a wide variety of rotary lobe pumps for pumping any fluid, macerating units for macerating different solids as well as stainless steel tanks with lasting value for storing different liquids.



ROTARY LOBE PUMPS

Börger is a specialist for rotary lobe pumps. We offer 25 pump sizes with flow rates of 1 – 1,500 m³/h and a large selection of equipment and additional parts. The large-scale geometry and short passage enable the medium to be pumped gently.

MOBILE PUMPS

The compact Börger pumps are especially suitable as cart pumps, high-performance pumps mounted on a trailer, on a tanker truck or as portable units.



CONTROL UNITS

On request, Börger provides a control unit which is perfectly configured for each specific product. The control technology is designed and programmed for the specific unit and its application by the in-house electrical engineering department.



STAINLESS STEEL TANKS

Börger stainless steel tanks in segmental design with capacities of 30 to 5,000 m³ are very well suited for storing different liquids.



MACERATING TECHNOLOGY

Börger provides suitable solutions for particle size reduction of solids contained in liquids. By offering three different macerators, the Multicrusher, Multichopper and Rotorrake, we are able to provide the ideal unit for every solid material to be macerated.



AGITATOR TECHNOLOGY

In order to homogenize liquids and prevent the formation and deposit of solids, the Börger submersible B-MX mixer agitates various fluids.

BÖRGER ROTARY LOBE PUMPS

ROBUST, RELIABLE AND CUSTOMIZED

Börger rotary lobe pumps have been used in the municipal and environmental technology sector for more than 25 years. The solids handling pumps are powerful, reliable and efficient. Börger pumps convey dirty, sludgy and abrasive media without problems.

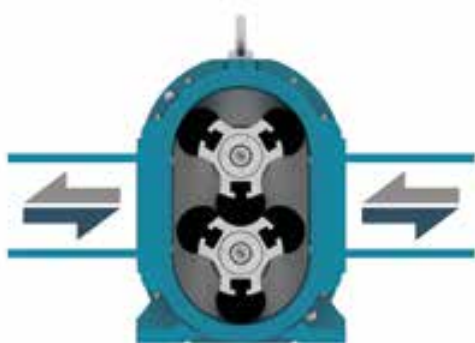

OPERATING PRINCIPLE

Börger rotary lobe pumps are self-priming, valveless, positive displacement pumps. The synchronized rotation of the rotor pair creates a vacuum on the priming side of the pump. This vacuum draws the liquid into the pump chamber. The medium is pumped into the pressure area due to the rotation of the rotors. If the direction of rotation is changed, the flow is reversed.

CONSTRUCTION

- 1 The quick-release cover**
Access to all wetted parts by simply loosening four ring nuts.
- 2 The rotors**
Large selection of high-quality rotors for almost pulsation-free pumping of the medium.
- 3 The casing protection**
The casing liners and casing protection plates protect the pump casing from wear and can be replaced in a matter of minutes.
- 4 The intermediate chamber and shaft seal**
The large-volume quench chamber is oil-filled and ensures the highest degree of safety. The ideal mechanical seal is selected depending on the medium.
- 5 The carrier and timing gear**
The high-quality and maintenance-free carrier and timing gear guarantees a smooth and even operation of the rotors. The result is a long service life of the pump.



ROTARY LOBE PUMPS AT A GLANCE

- + 25 pump sizes with flow rates of 1 – 1,500 m³/h
- + Self-priming, pumping in slurrp operation
 - + Resistant to solids
 - + Ease of maintenance (MIP)
- + Compact, space saving design
- + Cantilevered carrier design
- + Reversible

CASE STUDY: MEMBRANE FILTRATION

A membrane filtration system uses 8 Börger rotary lobe pumps which suck the water to be cleaned through the membranes. The membranes are cleaned by periodic back-flushing with filtered water. For this reason, it was important for the operator of the water treatment plant to use pumps which can be reversed. In addition, the pumps should have high suction capacity. As different quantities are pumped when operated in filtration mode compared to back-flushing mode Börger rotary lobe pumps are operated by means of a frequency converter controlling the pump speed.



MAXIMAL MODULAR VARIETY

NO BÖRGER PUMP IS LIKE ANY OTHER

No matter which application – Börger builds a suitable rotary lobe pump for you. With suitable materials, exactly aligned construction and design, whether with overhead mounted drive, submerged or as a mobile pump. Even individual solutions are a specialty of Börger.



25 PUMP SIZES WITH FLOW RATES OF UP TO 1,500 m³/h

The BLUEline and ONIXline models differ in flow and pressure ranges. The proven BLUEline incorporates flow rates up to 1,500 m³/h.

The newly developed ONIXline from Börger, designed for best efficiencies at pressures up to 16 bar.

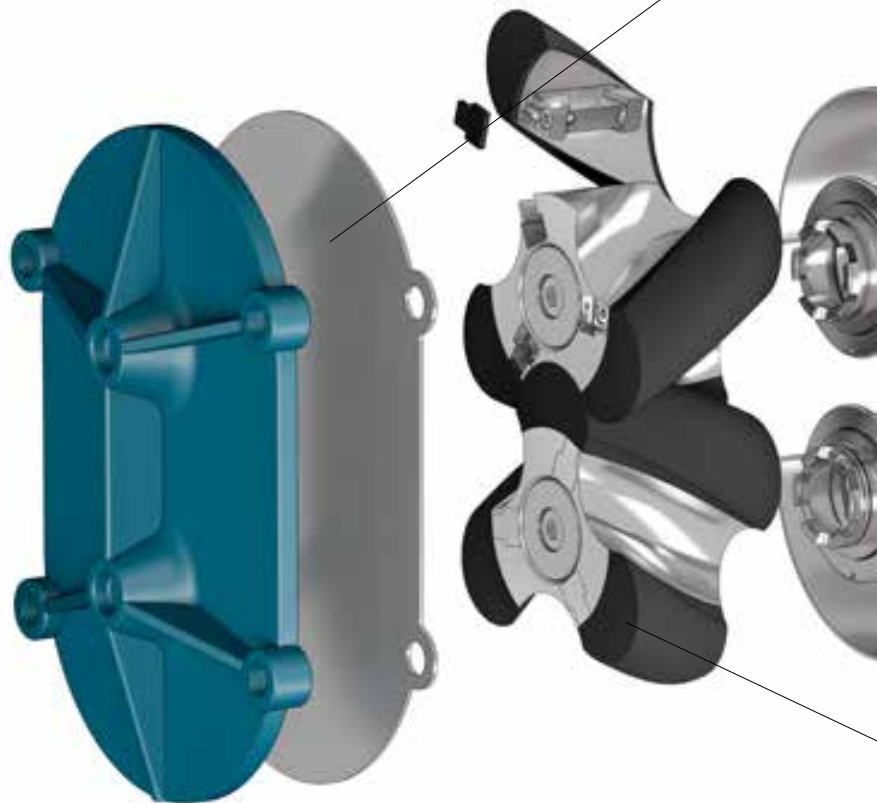

Börger rotary lobe pumps overview

Pump series	Speed in rpm		Flow rate in m ³ /h		Max. pressure in bar
	Min.	Max.	Min.	Max.	
BLUEline AL	50	600	1	28	12
BLUEline PL	50	600	3	130	12
BLUEline CL	50	600	8	188	12
BLUEline FL	50	600	18	410	12
BLUEline EL	50	600	32	1,100	10
BLUEline XL	50	600	52	1,500	10

Pump series	Speed in rpm		Flow rate in m ³ /h		Max. pressure in bar
	Min.	Max.	Min.	Max.	
ONIXline BJ	50	800	3	68	16
ONIXline BL	50	800	6	135	16



UNIQUE CASING PROTECTION

In order to prevent pump casing damage, e.g. due to abrasive or aggressive fluids, Börger pumps are equipped with casing protection. The unique casing liners and casing protection plates are available in different materials.



UNIQUE BLOCK DESIGN

All 25 pump models feature dedicated, non-segmented pump casings and rotors in single-piece (BLOCK) construction. This design reflects the high quality standard of Börger and guarantees long service life with ease of maintenance.

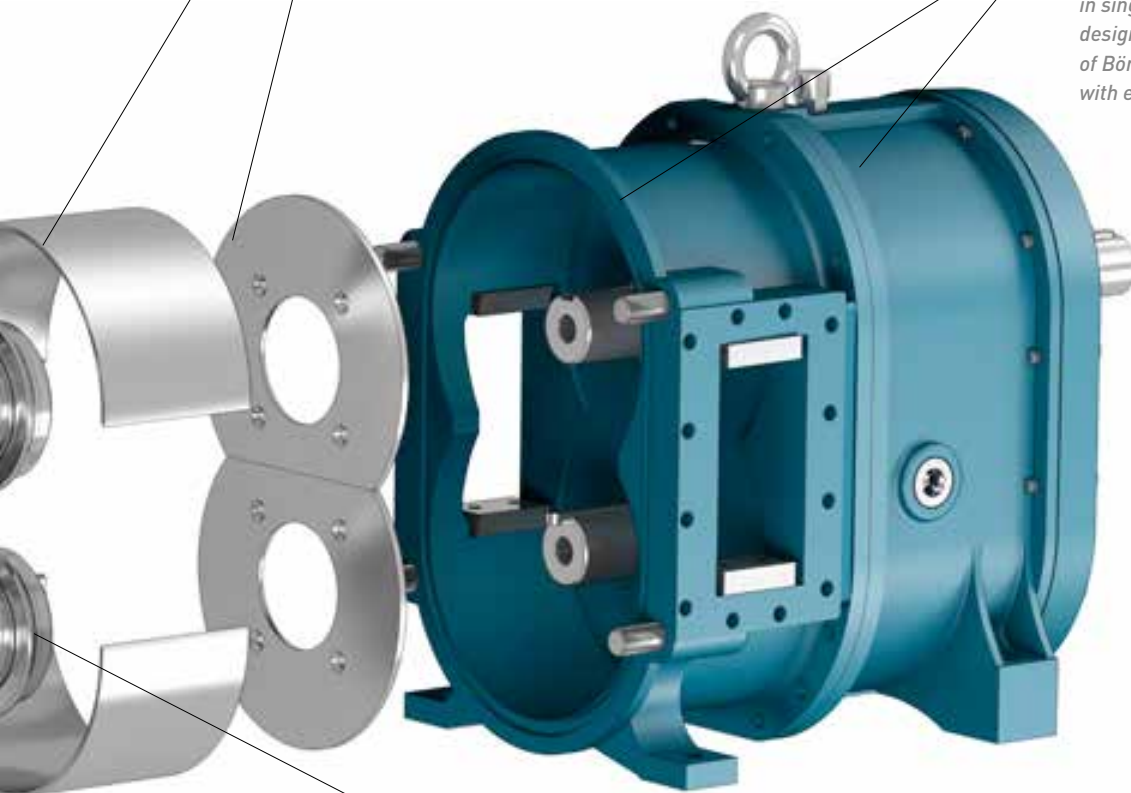

VARIETY OF ROTORS

Börger offers a comprehensive range of rotors differentiated by geometry and material. We offer a suitable rotor for your application.



HIGH-QUALITY SEALS

Our solids-resistant, single-acting mechanical seals ensure the highest degree of safety. Individual shaft seal solutions for challenging applications are possible.

DETAILED AND LARGE VARIETY OF MATERIALS

Börger offers a broad range of materials for all pump components. For example, the pump casing can be manufactured in cast iron, cast steel, Aluminium, stainless steel, Duplex steel or Hastelloy®.

AS VERSATILE AS YOUR TASKS

SUBMERGED PUMPS

The compact design, the chemical resistance and the ability to pump highly viscous media are reasons why the Börger rotary lobe pump is perfectly suited for submerged or semi-submerged applications. This is also an ideal solution if the NPSH a of the process system prohibits a dry pump installation.

DIFFERENT SKID DESIGNS

For pump system installations, the structural conditions plant site and required accessories need to be considered. Börger offers complete solutions. In addition to the rotary lobe pump itself, we also manufacture the pump skid components.

Individually made base frames and customized flange connections as well as stainless steel hoppers or feed augers are part of Börger's product portfolio. The mounting position of the pump / drive combination are selected according to plant requirements.

Börger supplies special pump systems or mobile unit "turn-key". The design, metal construction and electrical engineering departments are up to the challenge.

CONTROL PANEL TECHNOLOGY

Optional control panels are adapted to the customer's individual requirements by Börger's electrical engineering department.

You can easily control and monitor your rotary lobe pump via the control cabinet. The operation of a macerator including rotation reversing to prevent blockages is controlled by the electrical panel.

Additionally, the necessary control functions for using your rotary lobe pump in potentially hazardous environments can be monitored.



SUBMERGED PUMPS



SKID DESIGNS



**CONTROL PANEL
TECHNOLOGY**

MOBILE PUMPS FOR FLEXIBLE SERVICE

Many sectors require flexible, mobile pump systems for deployment on short notice. As versatile as mobile pump solutions from Börger are, they have one thing in common: they are configured to the customers specification.

The experience designing and building hundreds of mobile pump units is reflected in each Börger mobile pump. We offer complete solutions – the trailer, the pump technology and the electrical control.

Börger rotary lobe pumps can be equipped with an electric drive, a hydraulic motor or a combustion engine depending on the application. They can also be driven by PTO shaft of a vehicle.

Whether as a flexible hand cart pump, portable pump, high-performance pump on a trailer or compact tanker truck pump, Börger mobile units are ready on short notice. Simply connect the hoses and start the engine.

MOBILE PUMPS



MAINTENANCE IN PLACE (MIP)

SIMPLE. EASE OF MAINTENANCE.



Repairs and downtimes are time-consuming and costly. To maximize your production time with minimized interruptions, your operating and maintenance personnel can inspect and if necessary replace all product wetted parts onsite.

Börger pumps and macerators are designed for continuous operation and incorporate unbeatable ease of maintenance features. All components are extremely resilient and durable.

Expensive maintenance contracts? Not with Börger products. We offer MIP (Maintenance In Place). Control maintenance and repair procedures yourself. Product wetted parts can be inspected or replaced at the installation site without the need to remove piping and the drive system. Easily and quickly by your own personnel.



MULTICRUSHER

VERSATILE MACERATOR

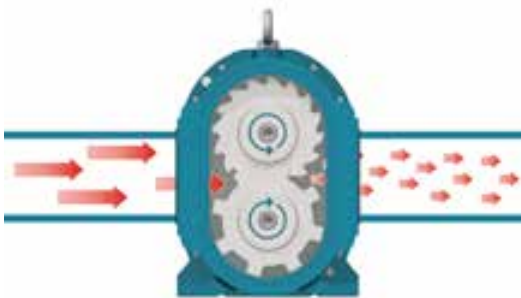

The dual-shaft grinder Multicrusher effectively and reliably processes solids contained in liquids and ensures that downstream machines and pumps operate smoothly.

OPERATING PRINCIPLE

The basic design of the dual-shaft grinder is based on the proven Börger rotary lobe pump. The two shafts are equipped with blades and spacers instead of rotors. The solids-laden medium passes through the counter-rotating blade configuration and is therefore macerated.

Börger Multicrusher overview

Multicrusher series	Max. capacity in m ³ /h	Max. pressure in bar
HAL	15	12
HPL	60	12
HCL	120	12
HFL	260	12



CONSTRUCTION

- 1 The quick-release cover**
 Access to all wetted parts through the quick-release cover – maintenance without removal of pipe or drive systems (MIP).
- 2 The blades**
 The degree of maceration of the Börger Multicrusher depends on the blade selection, selected blade tooth shapes, blade thickness, arrangement of the blades and operational speed of the Multicrusher.
- 3 The intermediate chamber**
 The large-volume quench chamber is filled with oil and ensures the highest degree of safety.
- 4 The carrier gear and gear reducer**
 The different circumferential speeds of the carrier shafts and the sharp blades create an excellent cutting result.



MULTICRUSHER AT A GLANCE

- + Variable degree of maceration due to flexible blade combinations
- + Compact, space saving design
- + Available in stainless steel
- + Low life-cycle costs
- + Long service life

CASE STUDY: PRIMARY SLUDGE CONVEYANCE

In order to macerate the solids in the primary sludge before the sludge is further processed, a Multicrusher is installed upstream of the Börger primary sludge pumps on the suction side. The treatment plant operator was particularly impressed by the degree of safety, maceration result and operation almost without wear.



MULTICHOPPER

FINE MACERATION OF SOLIDS



The Börger Multichopper is a perforated disk macerator with a central, perforated plate and high-performance blades for size reduction of solids contained in liquids. The macerator is available in three sizes with capacities of up to 400 m³/h.

OPERATING PRINCIPLE

A pump transfers solids containing liquids through the Multichopper. Blades rotate on a perforated plate inside the macerator. The blades encounter the solids passing through the perforated plate resulting in particle size reduction. The reduced solids then continue to flow suspended in the liquid.

Börger Multichopper overview

Multichopper plus	Max. capacity in m ³ /h	Max. pressure in bar
P150	80	5
P300	220	5
P500	400	5
Multichopper pure	Max. capacity in m ³ /h	Max. pressure in bar
P150	80	5
P300	220	5

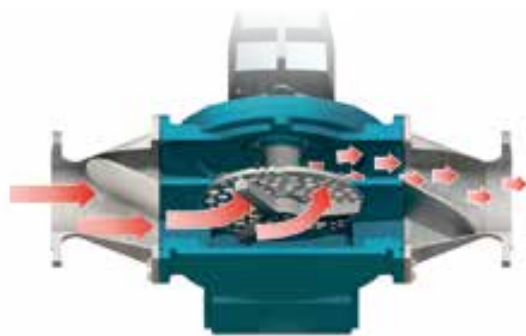

CONSTRUCTION

- 1 The quick-release cover**
 Access to all wetted parts through the quick-release cover – maintenance without removal of pipe or drive systems (MIP).
- 2 The blade unit**
 The three-blade knifehead rotates on the perforated disk. The blades have multiple cutting edges and can be turned around for longer service life.
- 3 The perforated disk**
 Various perforated disks are available depending on the maceration result required. The rotational speed and fluid velocity also affect the maceration result. The perforated disks can be reversed and used from both sides.
- 4 The foreign body separator**
 The Multichopper is available with or without foreign body separator (With drainage device at the side).
- 5 The MCA unit (Mechanical Cut Adjustment)**
 The externally mounted MCA unit guarantees an ideal contact pressure of the blades against the perforated disk. The result: an optimal cutting effect.

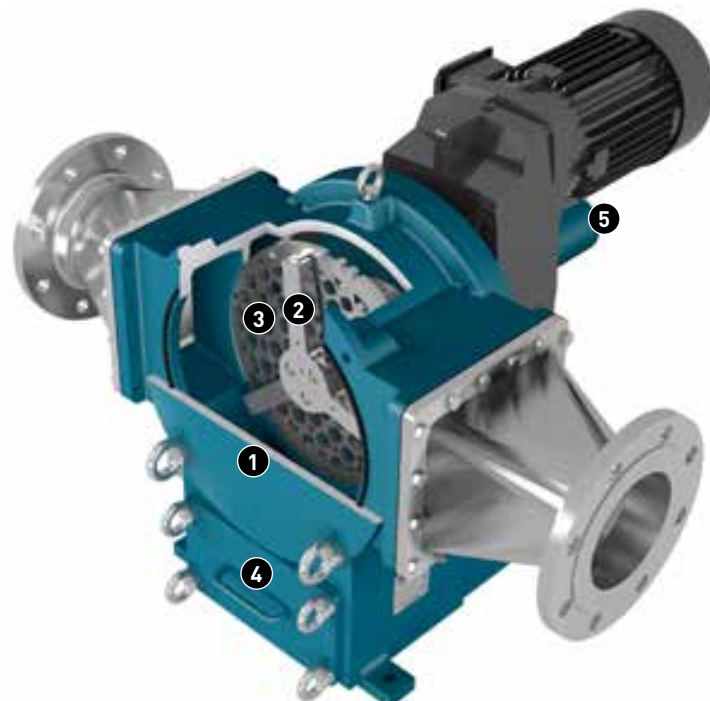

MULTICHOPPER AT A GLANCE

- + Different perforated disks
- + Automatic MCA unit
- + Optional foreign body separator
- + Can be supplied in stainless steel
- + Low life-cycle costs
- + High degree of maceration

CASE STUDY: MACERATING SOLIDS IN FATS, OIL AND GREASE

Grease from the grease separators from surrounding industrial and municipal waste water treatment plants are delivered by means of liquid transporters. The Multichopper reliably macerates the solids contained in the grease before the grease is conveyed to a storage container. Reliable continuous operation is guaranteed due to the long service life and low-maintenance design of the Multichopper.



ROTORRAKE

ROBUST SINGLE-SHAFT COARSE MACERATOR



The Rotorrake tackles macerating tasks where others have failed – for macerating very coarse solids and rags. Coarse objects which cannot be macerated are ejected into the foreign body separator.

OPERATING PRINCIPLE

The solids containing liquids flow through the stationary counter blades which are arranged at an angle. The solids are captured by the counter blades and shredded by the cutting action of the rotating blades. The reduced solids then continue to flow suspended in the liquid.

Börrer Rotorrake overview

Rotorrake	Max. capacity in m ³ /h	Max. pressure in bar
RR 6000	360	5
RR 9000	540	5



CONSTRUCTION

- 1 The quick-release cover**
Access to all wetted parts through the quick-release cover – maintenance without removal of pipe or drive system (MIP).
- 2 The blades and counter blades**
Blades and counter blades are assembled alternately on the carrier shaft. The rotational blades are moved by the shaft. The stationary counter blades are locked into the casing.
- 3 The foreign body separator**
Solids that cannot be macerated are collected in the foreign body separator (With drainage device at the side).



ROTORRAKE AT A GLANCE

- + Effective coarse macerator
- + High resistance to wear due to no-contact arrangement of blades and counter blades
- + Blades and counter blades can be turned round for longer service life
- + Available in stainless steel
- + Energy efficient

CASE STUDY: ANAEROBIC DIGESTION RECIRCULATION

A waste water treatment plant was having problems with rag buildup in their biosolids. The macerators used were not able to handle the large rag accumulations and to reduce these into smaller pieces. Frequent digester recirculation pump blockages were the result. The plant operator decided to install a Börger Rotorrake upstream of the pumps. There have been no pump blockages since that day. The operation of the Rotorrake has been trouble-free for more than two years.



B-MX SUBMERSIBLE MIXER FOR EFFECTIVE AGITATION



The B-MX submersible mixer ensures that liquid media with solids is effectively agitated.

OPERATING PRINCIPLE

The slim design and smooth surface of the device allows liquid to flow to the displacement blades without creating turbulence. This guarantees high efficiency. The high-precision casing and all wetted parts are made of stainless steel.

SUBMERSIBLE MIXER AT A GLANCE

- + Various sizes
- + Completely made of stainless steel
- + Good flow pattern to the propellers
- + Cable routing at the protected back end of the mixer
- + High efficiency

Börger Submersible Mixer overview

B-MX	Output in kW	Output in m ³ /h	Speed in rpm	Weight in kg
B-MX 9	9	3780	325	120
B-MX 13	13	5020	335	165
B-MX 18	18	6860	335	185

The slim, edge-free design of the B-MX and the geometry of the propeller blades have been optimized by means of the latest flow simulation programs and ensure highest efficiency.

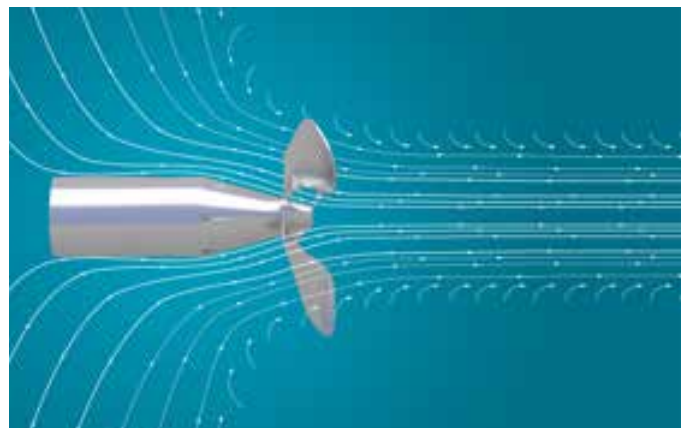

STAINLESS STEEL TANKS FOR STORING LIQUIDS

Börger stainless steel tanks available in different materials grades are suitable for storing any liquid.

Capacities between 30 to 5,000 m³, various accessories and roof constructions allow a customized, customer centered solution. The storage size can be increased without problems due to the segmented tank design.

STAINLESS STEEL TANK AT A GLANCE

- + Capacity of 30 to 5,000 m³
- + Maintenance-free and lasting value
- + Can be increased and disassembled
- + Different roof constructions
- + Versatile function



BÖRGER®

EXCELLENCE – MADE TO LAST

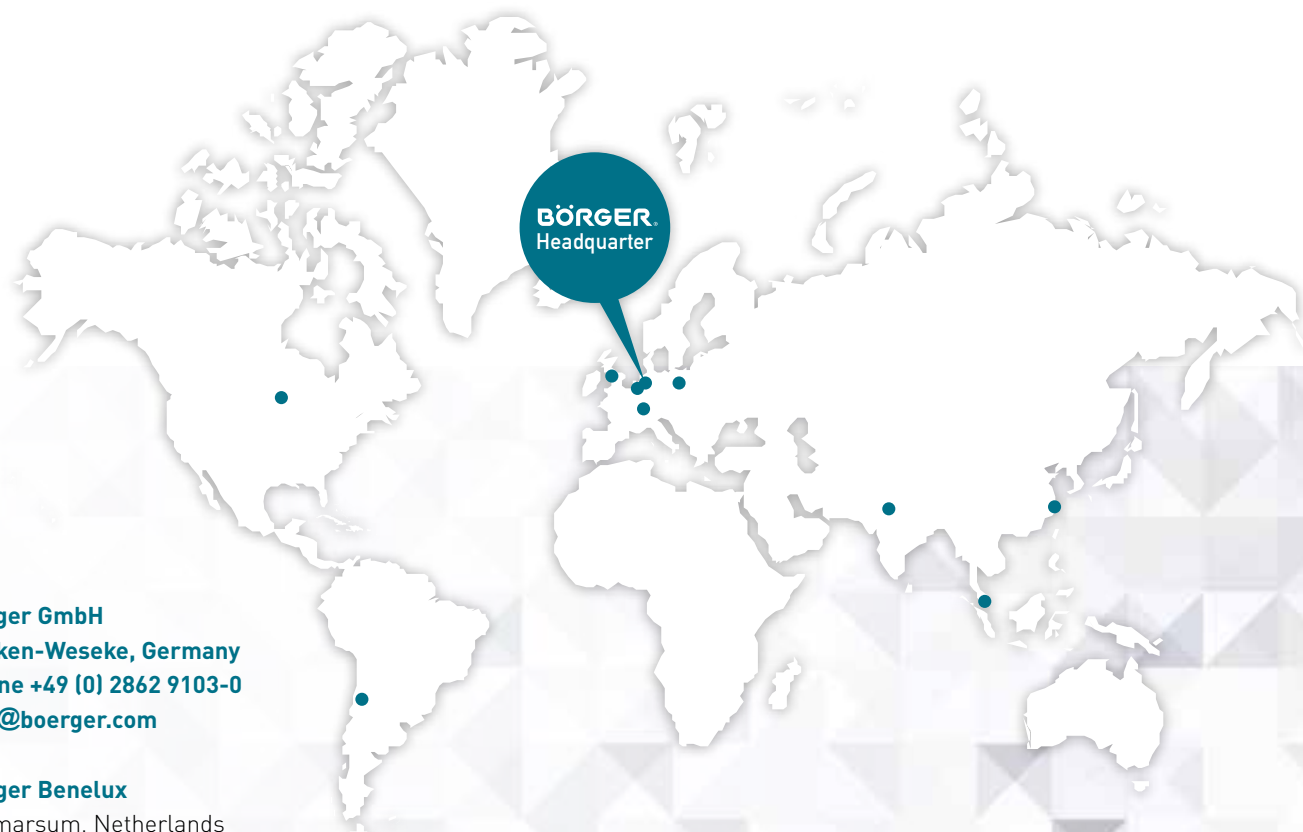

Börger GmbH
Borken-Weseke, Germany
Phone +49 (0) 2862 9103-0
info@boerger.com

Börger Benelux
Ootmarsum, Netherlands
info@boerger-pumps.nl

Börger France S.A.R.L.
Wittersheim, France
info@boerger.fr

Boerger Polska Sp. z o.o.
Gliwice, Poland
info@boerger.pl

Börger UK Limited
Staffordshire, United Kingdom
uk@boerger.com

Boerger, LLC
Chanhassen, MN, USA
america@boerger.com

Boerger LLC
Concepción, Chile
america@boerger.com

Boerger Pumps (Shanghai) Co. Ltd.
Pudong, Shanghai, China
shanghai@boerger.com

Boerger Pumps Asia Pte Ltd
Singapore
asia@boerger.com

Boerger Pumps Asia Pte Ltd
Gurgaon, Haryana, India
india@boerger.com

www.boerger.com

lobe

Danmark
Lobe ApS
Tlf. +45 7684 3484
Mail: sales@lobe.dk
www.lobe.dk

Norge
Lobe AS
Tlf. +47 6710 5000
Mail: sales@lobe.no
www.lobe.no

B15_04_2017