

# Verderhus Stainless Steel

## HSB-150-100-A

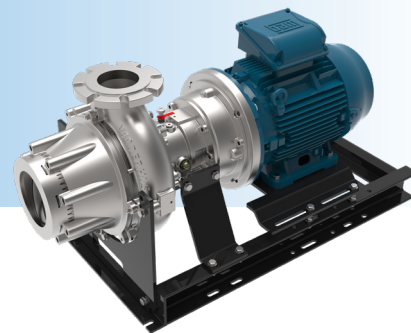

VERDERHUS®

### Description

Verderhus stainless steel screw centrifugal pumps combine the best features of centrifugal and positive displacement pumps. They define a new standard for low head, high flow pumps. The Verderhus pumps have a large clearance screw impeller, which gently feeds product into the pump chamber. This allows the product to be efficiently transferred into the discharge line and allows for large solids to be easily pumped. The screw design impeller is ideal for high solid contents and viscous liquids. It produces a high efficiency, low NPSHr pump, lowering both energy usage and operational costs, generating a lower overall cost of ownership.

### Features and benefits

- Large solid handling with <10% sludge, <30% slurry
- Gentle, low shear pumping, meaning lesser damage to the fluid
- Low energy use compared to other technologies
- Low abrasive wear meaning reduced maintenance costs
- Corrosion resistant stainless steel for aggressive chemical handling

### Technical data

Ambient operating temperature	-5, 40 °C	Max viscosity	3000 cP
Fluid temperature	-20, 100 °C	Maximum solid size	80 mm
Maximum pump noise	up to 75 dB	Solid content percentage	Sludge: 10% - Slurry: 30%
Max. flows	300 m <sup>3</sup> /h	Max. head	22 mwc

### Performance curve

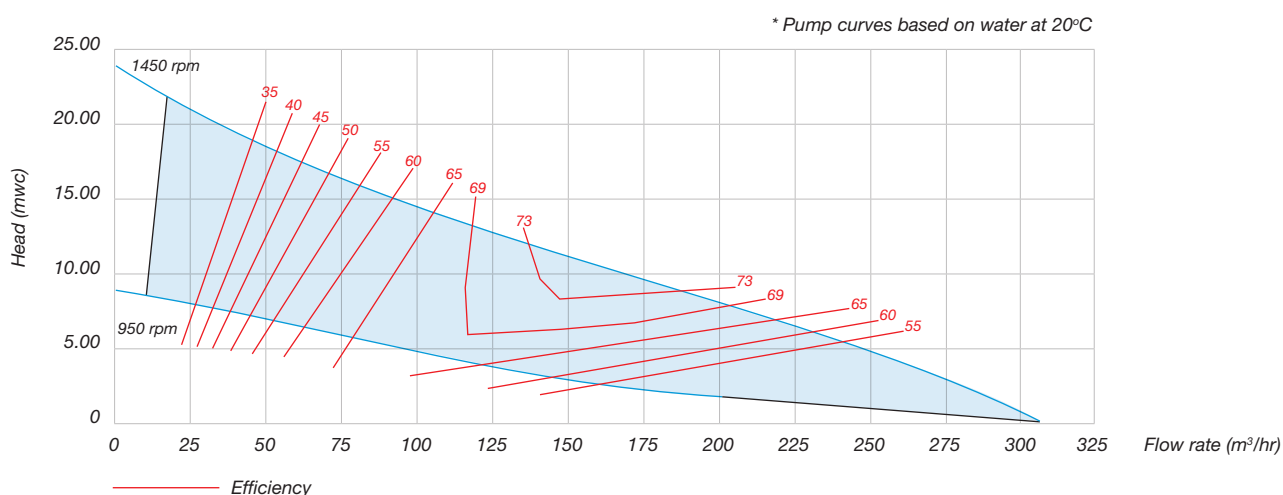

# Verderhus Stainless Steel

## HSB-150-100-A

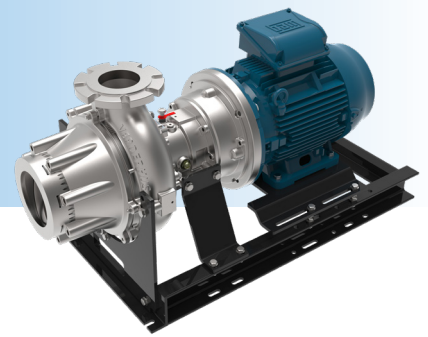

VERDERHUS®

Item No.	Description	Standard Materials / Dimensions
1	Impeller housing/Cone*	Stainless Steel 1.4408 (316) (Nitrided)
	Suction flange	DN150 PN10
	Discharge flange	DN100 PN10
2	Intake Socket*	Stainless Steel 1.4408 (316) (Nitrided)
3	Impeller*	Stainless Steel 1.4408 (316) (Nitrided)
4	Cooling Flange*	Stainless Steel 1.4408 (316) (Nitrided)
5	Bearing housing*	Stainless Steel 1.4408 (316) (Nitrided)
6	Transition flange	Stainless Steel 1.4408 (316)
7	Drive shaft	Stainless Steel 1.4435 (AISI 316L)
8	Bearing	Single Row Deep Groove Ball Race-Sealed for Life
9	Mechanical seal-product side	Silicon Carbide/Silicon Carbide/VITON
10	Mechanical seal-motor side	Carbon/Ceramic/NBR
11	Oil Chamber	Industrial gear oil 150
12	O-rings material	FPM
13	Motor options and overall pump weight (WEG W22 IE3 motors)	With IEC132 Motor: 248 Kg    With IEC160 Motor: 387 Kg
	Mounting frame	Steel S275 JR

\* Impeller housing, Intake socket, Impellers, Bearing housing and Cooling flange will now be Nitrided as standard to increase wear resistance and surface hardness.

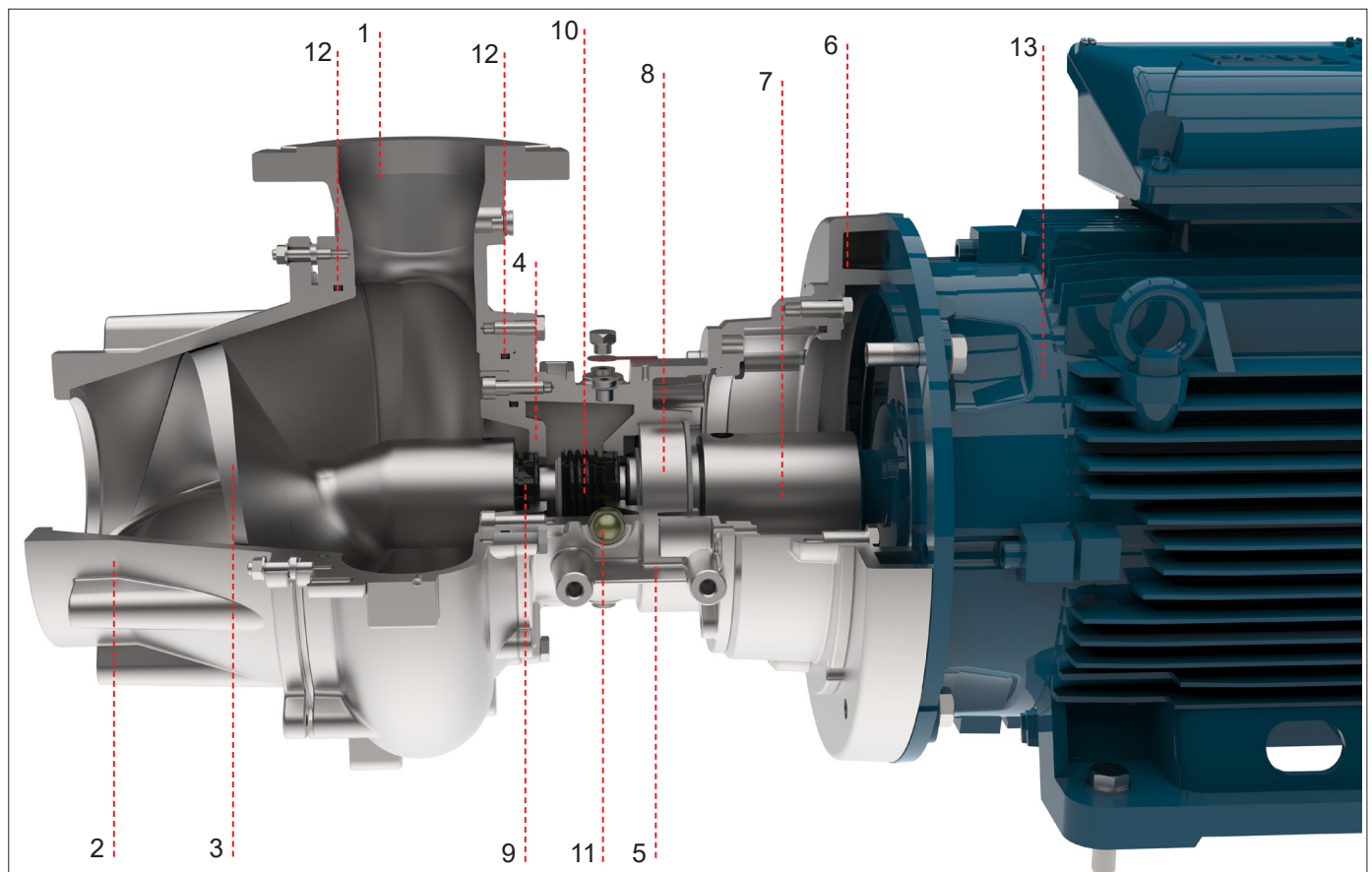

Sectional view of Impeller Housing Assembly



# Verderhus Stainless Steel

## HSB-150-100-A



VERDERHUS®

### Dimensions

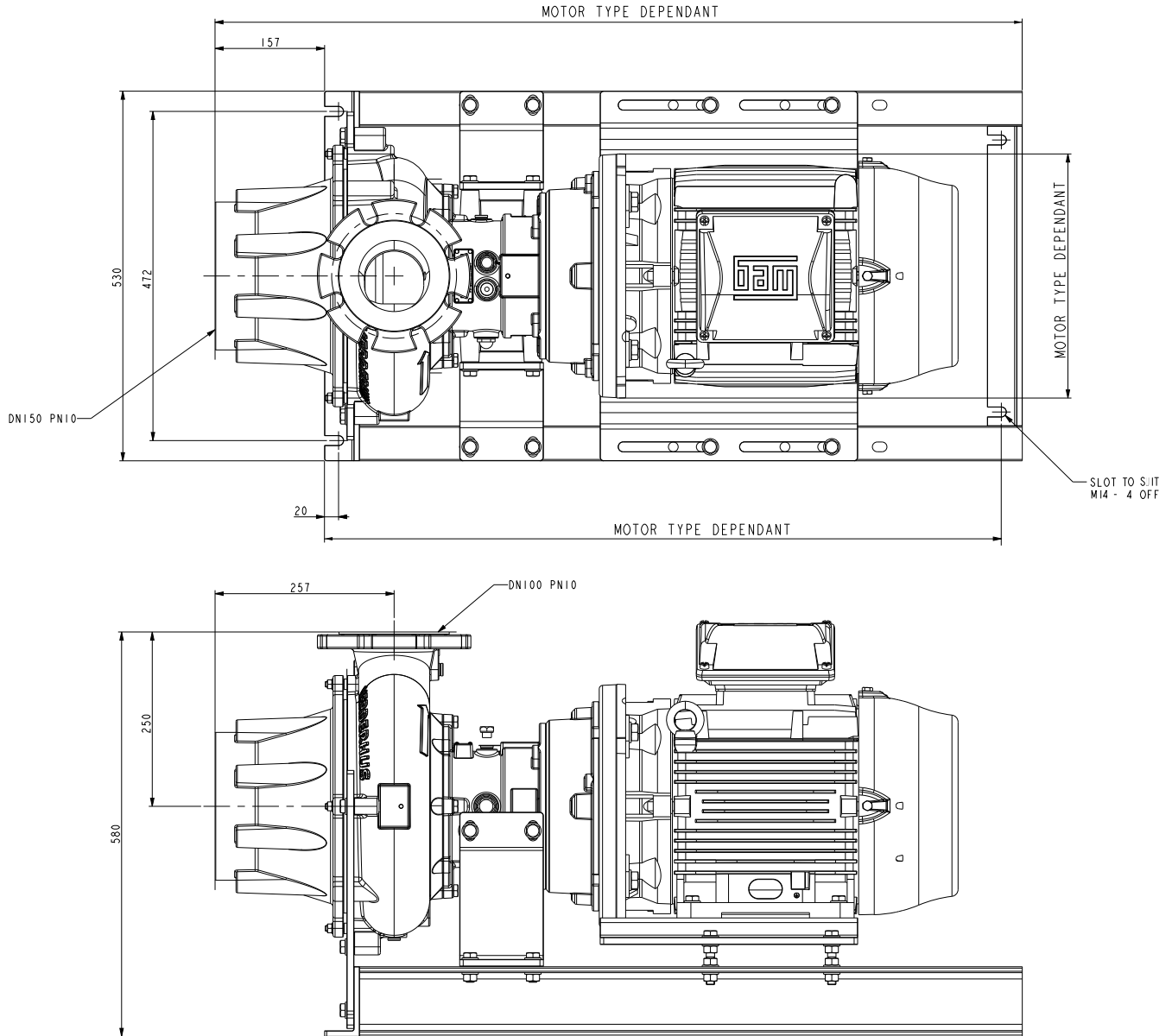

All dimensions are in mm.

All dimensions and weights are for guidance only.

Your local supplier:

# lobē

**Danmark**  
Fabriksvej 13 - 15  
DK 6580 Vamdrup  
Tel: (+45) 76 84 34 84  
web: [www.lobe.dk](http://www.lobe.dk)

**Norge**  
Slemmestad veien 416 A  
NO 1390 Vollen  
Tel: (+47) 92 02 16 66  
web: [www.lobe.dk](http://www.lobe.dk)

**VERDER**  
passion for pumps



# Verderhus Stainless Steel

## HSB-150-100-B



VERDERHUS®

### Description

Verderhus stainless steel screw centrifugal pumps combine the best features of centrifugal and positive displacement pumps. They define a new standard for low head, high flow pumps. The Verderhus pumps have a large clearance screw impeller, which gently feeds product into the pump chamber. This allows the product to be efficiently transferred into the discharge line and allows for large solids to be easily pumped. The screw design impeller is ideal for high solid contents and viscous liquids. It produces a high efficiency, low NPSHr pump, lowering both energy usage and operational costs, generating a lower overall cost of ownership.

### Features and benefits

- Large solid handling with <10% sludge, <30% slurry
- Gentle, low shear pumping, meaning lesser damage to the fluid
- Low energy use compared to other technologies
- Low abrasive wear meaning reduced maintenance costs
- Corrosion resistant stainless steel for aggressive chemical handling

### Technical data

Ambient operating temperature	-5, 40 °C	Max viscosity	3000 cP
Fluid temperature	-20, 100 °C	Maximum solid size	80 mm
Maximum pump noise	up to 75 dB	Solid content percentage	Sludge: 10% - Slurry: 30%
Max. flows	360 m <sup>3</sup> /h	Max. head	23 mwc

### Performance curve

\* Pump curves based on water at 20°C

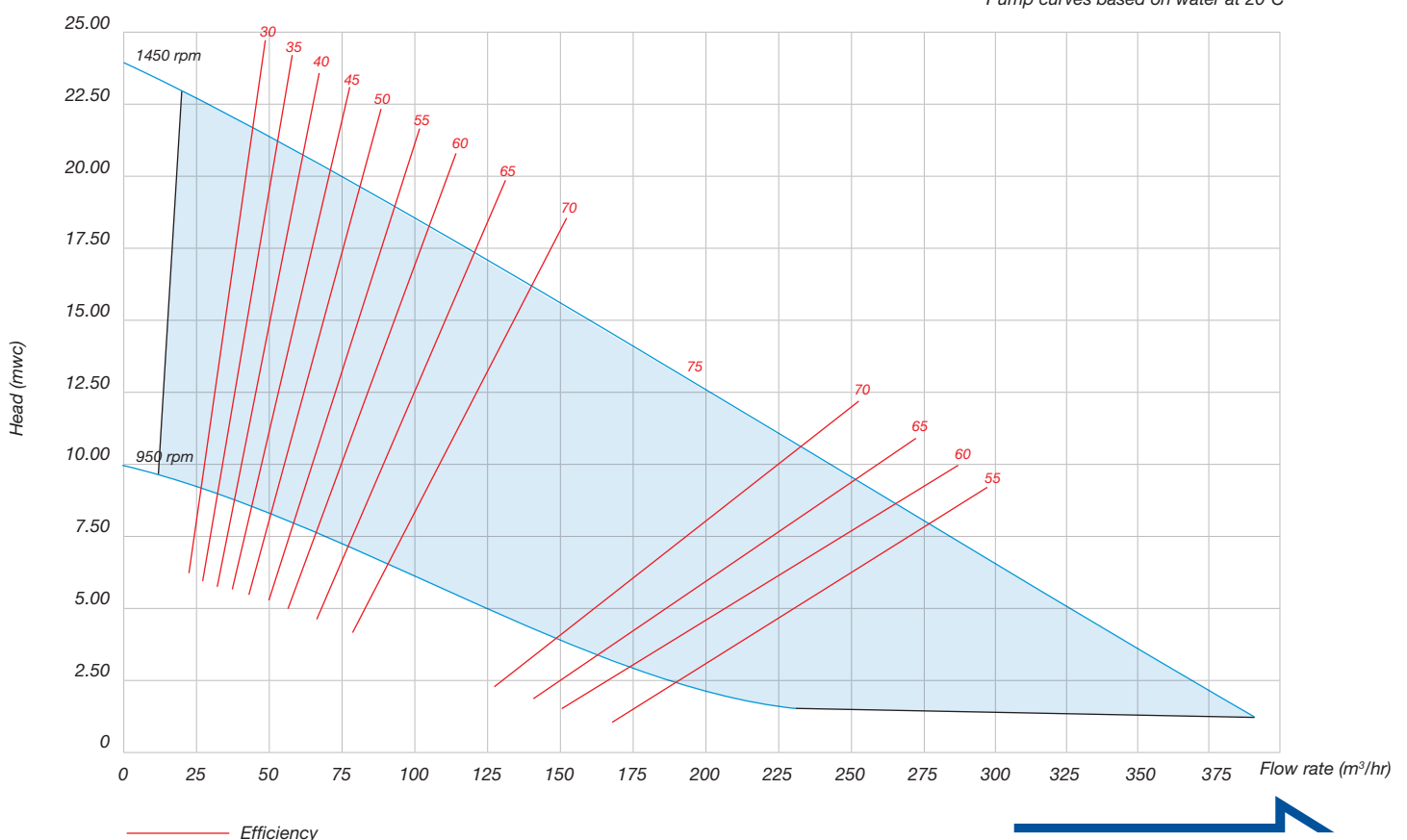

# Verderhus Stainless Steel

## HSB-150-100-B

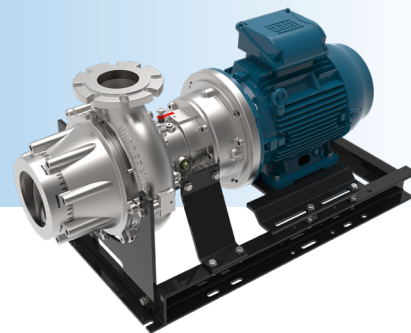

VERDERHUS®

Item No.	Description	Standard Materials / Dimensions
1	Impeller housing/Cone*	Stainless Steel 1.4408 (316) (Nitrided)
	Suction flange	DN150 PN10
	Discharge flange	DN100 PN10
2	Intake Socket*	Stainless Steel 1.4408 (316) (Nitrided)
3	Impeller*	Stainless Steel 1.4408 (316) (Nitrided)
4	Cooling Flange*	Stainless Steel 1.4408 (316) (Nitrided)
5	Bearing housing*	Stainless Steel 1.4408 (316) (Nitrided)
6	Transition flange	Stainless Steel 1.4408 (316)
7	Drive shaft	Stainless Steel 1.4435 (AISI 316L)
8	Bearing	Single Row Deep Groove Ball Race-Sealed for Life
9	Mechanical seal-product side	Silicon Carbide/Silicon Carbide/VITON
10	Mechanical seal-motor side	Carbon/Ceramic/NBR
11	Oil Chamber	Industrial gear oil 150
12	O-rings material	FPM
13	Motor options and overall pump weight (WEG W22 IE3 motors)	With IEC132 Motor: 248 Kg    With IEC160 Motor: 387 Kg With IEC180 Motor: 450 Kg
	Mounting frame	Steel S275 JR

\* *Impeller housing, Intake socket, Impellers, Bearing housing and Cooling flange will now be Nitrided as standard to increase wear resistance and surface hardness.*

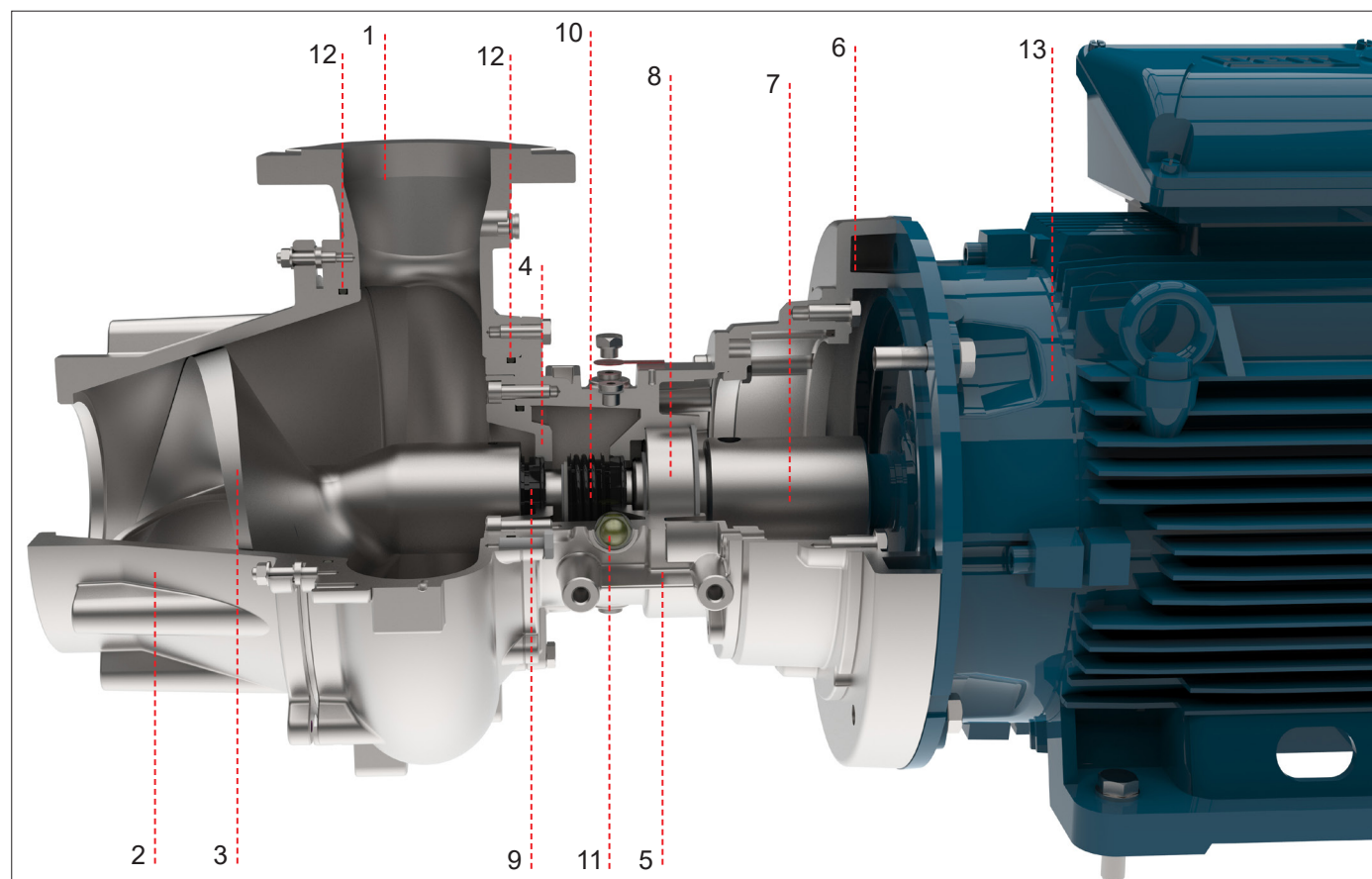

Sectional view of Impeller Housing Assembly



# Verderhus Stainless Steel

## HSB-150-100-B



VERDERHUS®

### Dimensions

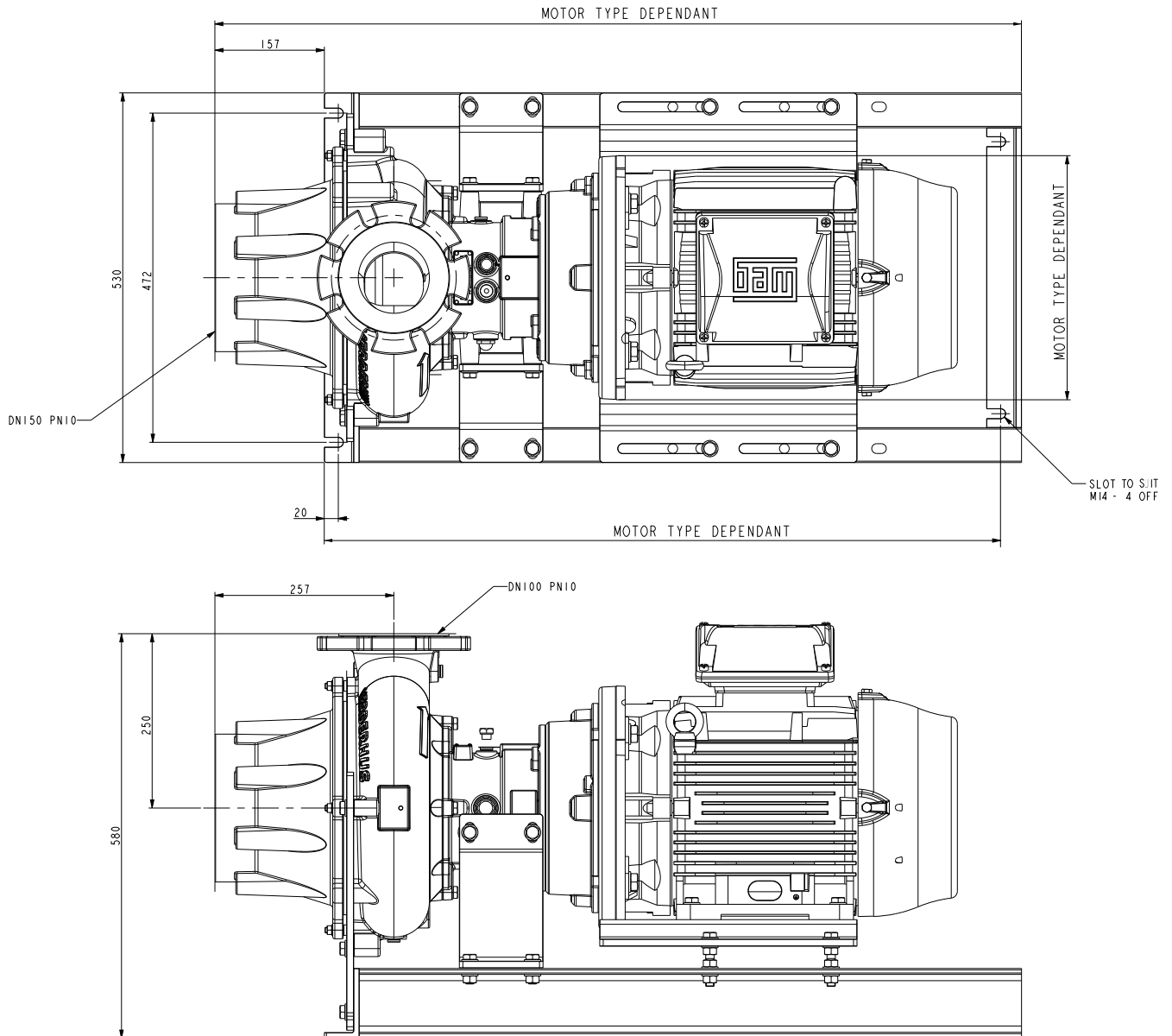

All dimensions are in mm.

All dimensions and weights are for guidance only.

Your local supplier:

# lobē

**Danmark**  
Fabriksvej 13 - 15  
DK 6580 Vamdrup  
Tel: (+45) 76 84 34 84  
web: [www.lobe.dk](http://www.lobe.dk)

**Norge**  
Slemmestad veien 416 A  
NO 1390 Vollen  
Tel: (+47) 92 02 16 66  
web: [www.lobe.dk](http://www.lobe.dk)

**VERDER**  
passion for pumps

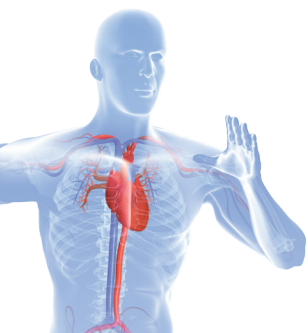

# Verderhus Stainless Steel

## HSB-150-100-C



VERDERHUS®

### Description

Verderhus stainless steel screw centrifugal pumps combine the best features of centrifugal and positive displacement pumps. They define a new standard for low head, high flow pumps. The Verderhus pumps have a large clearance screw impeller, which gently feeds product into the pump chamber. This allows the product to be efficiently transferred into the discharge line and allows for large solids to be easily pumped. The screw design impeller is ideal for high solid contents and viscous liquids. It produces a high efficiency, low NPSHr pump, lowering both energy usage and operational costs, generating a lower overall cost of ownership.

### Features and benefits

- Large solid handling with <10% sludge, <30% slurry
- Gentle, low shear pumping, meaning lesser damage to the fluid
- Low energy use compared to other technologies
- Low abrasive wear meaning reduced maintenance costs
- Corrosion resistant stainless steel for aggressive chemical handling

### Technical data

Ambient operating temperature	-5, 40 °C	Max viscosity	3000 cP
Fluid temperature	-20, 100 °C	Maximum solid size	80 mm
Maximum pump noise	up to 75 dB	Solid content percentage	Sludge: 10% - Slurry: 30%
Max. flows	360 m³/h	Max. head	24 mwc

### Performance curve

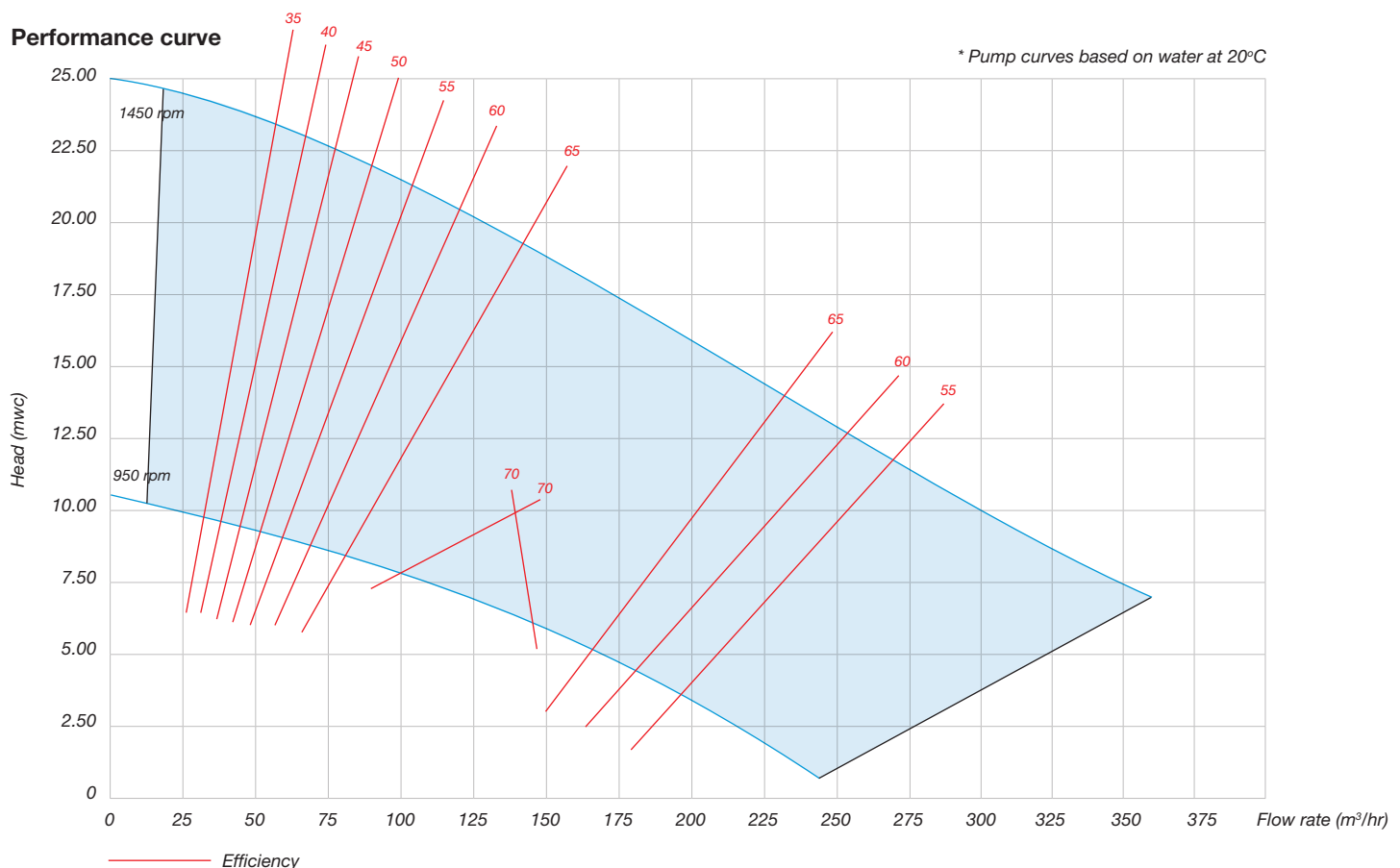

# Verderhus Stainless Steel

## HSB-150-100-C

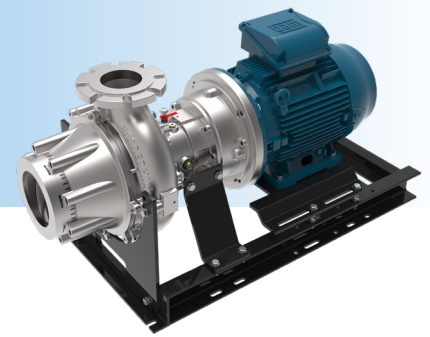

VERDERHUS®

Item No.	Description	Standard Materials / Dimensions
1	Impeller housing/Cone* Suction flange	Stainless Steel 1.4408 (316) (Nitrided) DN150 PN10
	Discharge flange	DN100 PN10
2	Intake Socket*	Stainless Steel 1.4408 (316) (Nitrided)
3	Impeller*	Stainless Steel 1.4408 (316) (Nitrided)
4	Cooling Flange*	Stainless Steel 1.4408 (316) (Nitrided)
5	Bearing housing*	Stainless Steel 1.4408 (316) (Nitrided)
6	Transition flange	Stainless Steel 1.4408 (316)
7	Drive shaft	Stainless Steel 1.4435 (AISI 316L)
8	Bearing	Single Row Deep Groove Ball Race-Sealed for Life
9	Mechanical seal-product side	Silicon Carbide/Silicon Carbide/VITON
10	Mechanical seal-motor side	Carbon/Ceramic/NBR
11	Oil Chamber	Industrial gear oil 150
12	O-rings material	FPM
13	Motor options and overall pump weight (WEG W22 IE3 motors)	With IEC132 Motor: 248 Kg    With IEC160 Motor: 387 Kg
	Mounting frame	Steel S275 JR

\* *Impeller housing, Intake socket, Impellers, Bearing housing and Cooling flange will now be Nitrided as standard to increase wear resistance and surface hardness.*

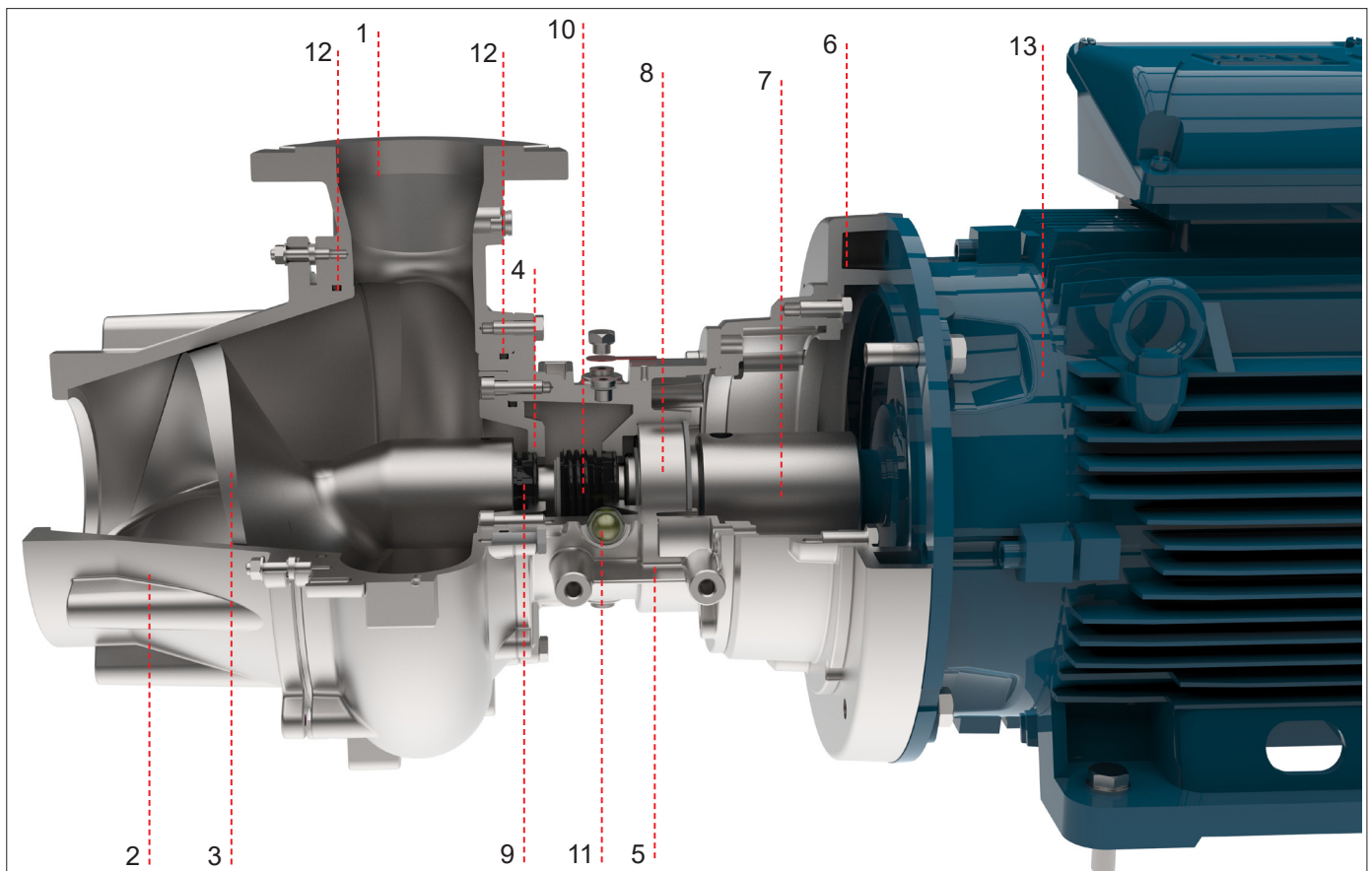

Sectional view of Impeller Housing Assembly





# Verderhus Stainless Steel

## HSB-150-100-C

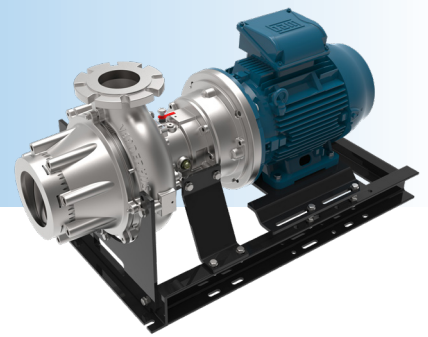

VERDERHUS®

### Dimensions

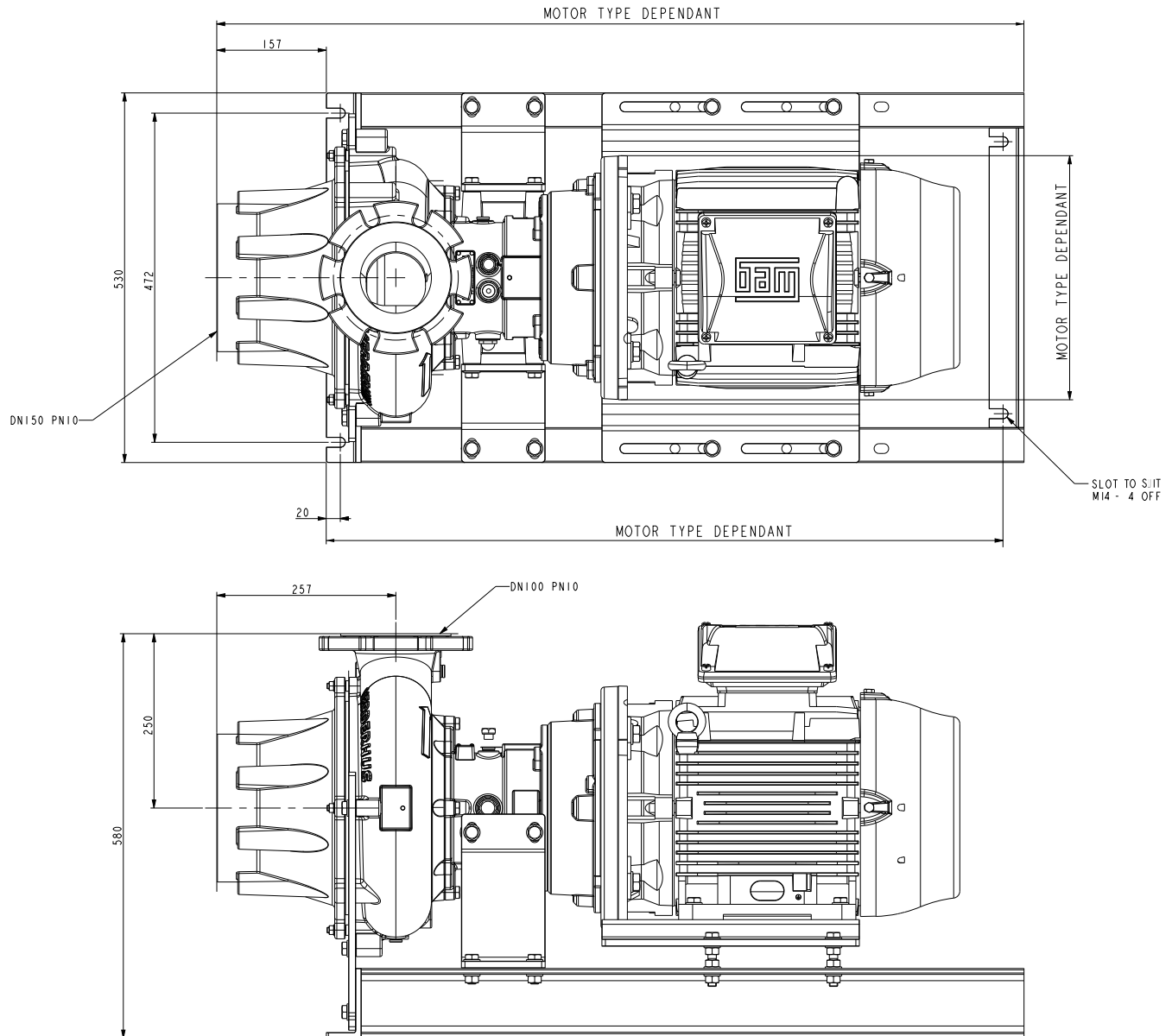

All dimensions are in mm.

All dimensions and weights are for guidance only.

Your local supplier:

# lobē

**Danmark**  
Fabriksvej 13 - 15  
DK 6580 Vamdrup  
Tel: (+45) 76 84 34 84  
web: [www.lobe.dk](http://www.lobe.dk)

**Norge**  
Slemmestad veien 416 A  
NO 1390 Vollen  
Tel: (+47) 92 02 16 66  
web: [www.lobe.dk](http://www.lobe.dk)

**VERDER**  
passion for pumps

