

# VERDERAIR VA 25

## Air-Operated Diaphragm Pump

859.0088

Rev. R  
EN

**1-inch pump with modular air valve for fluid transfer applications.  
For professional use only.**

**See page 3 for model information, including approvals.**

125 psi (0.86 MPa, 8.6 bar) Maximum Fluid Working Pressure

125 psi (0.86 MPa, 8.6 bar) Maximum Air Input Pressure



### Important Safety Instructions

Read all warnings and instructions in this manual. Save these instructions.

Polypropylene  
Conductive  
Polypropylene  
PVDF

Center  
Flange

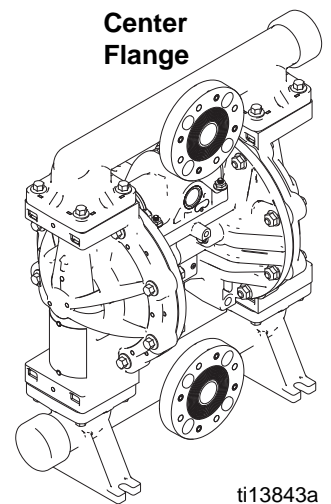

ti13843a

Aluminum

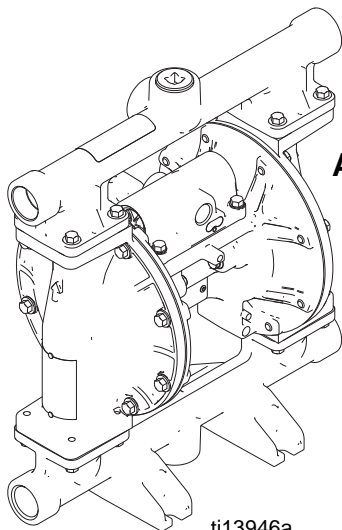

ti13946a

Stainless Steel  
Hastelloy

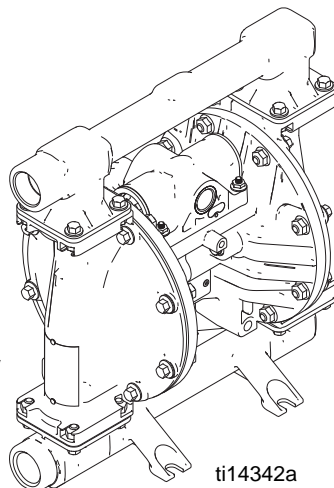

ti14342a

End  
Flange

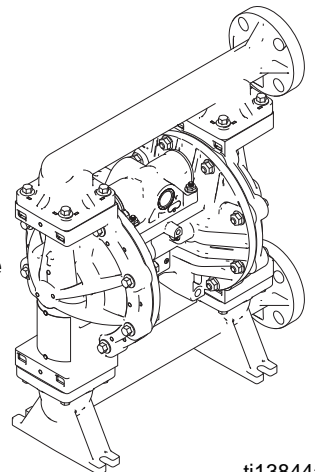

ti13844a

## Contents

<b>Related Manuals</b> .....	<b>2</b>	<b>Maintenance</b> .....	<b>16</b>
<b>Pump Matrix</b> .....	<b>3</b>	Maintenance Schedule .....	16
<b>ATEX Certifications</b> .....	<b>4</b>	Lubrication .....	16
<b>Warnings</b> .....	<b>4</b>	Tighten Threaded Connections .....	16
<b>Installation</b> .....	<b>7</b>	Flushing and Storage .....	16
Tighten Fasteners Before Setup .....	7	Torque Instructions .....	17
Mounting .....	7	<b>Dimensions and Mounting</b> .....	<b>18</b>
Grounding .....	7	Aluminum (VA25AA) .....	18
Air Line .....	8	Polypropylene (VA25PP),	
Reed Switch .....	9	Conductive Polypropylene (VA25CC),	
Air Exhaust Ventilation .....	9	and PVDF (VA25KP), Center Flange .....	19
Fluid Supply Line .....	10	Polypropylene (VA25PP),	
Fluid Outlet Line .....	10	Conductive Polypropylene (VA25CC),	
Fluid Inlet and Outlet Ports .....	13	and PVDF (VA25KP), End Flange .....	20
Fluid Pressure Relief Valve .....	14	Hastelloy (VA25HC) and Stainless Steel	
<b>Operation</b> .....	<b>15</b>	(VA25SA, VA25SC, and VA25SP) .....	21
Pressure Relief Procedure .....	15	<b>Performance Charts</b> .....	<b>22</b>
Flush the Pump Before First Use .....	15	<b>Technical Data</b> .....	<b>23</b>
Tighten Fasteners Before Setup .....	15	<b>Customer Services/Guarantee</b> .....	<b>27</b>
Starting and Adjusting the Pump .....	15		
Pump Shutdown .....	16		

## Related Manuals

Manual	Description
<b>859.0089</b>	<b>VERDERAIR</b> VA 25 Air-Operated Diaphragm Pump, Repair/Parts

# Pump Matrix

Check the identification plate (ID) for the 17-digit Configuration Number of your pump. Use the following matrix to define the components of your pump.

**Sample Configuration Number: VA25AA-SSBNBNTB00**

<b>VA25</b>	<b>A</b>	<b>A</b>	<b>SS</b>	<b>BN</b>	<b>BN</b>	<b>TB</b>	<b>00</b>
Pump Model	Fluid Section	Air Section	Seats	Balls	Diaphragms	Connections	Options

**NOTE:** Some combinations are not possible. Please check with your local supplier or the pump configurator on [www.verderair.com](http://www.verderair.com).

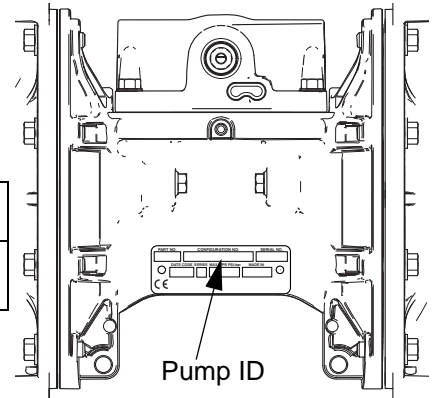

ti14103a

Pump Model	Fluid Section Material		Air Section Material		Check Valve Material		Check Valve Balls	
	<b>VA25</b>	<b>A</b>	Aluminum★	<b>A</b>	Aluminum	<b>AC</b>	Acetal	<b>AC</b>
	<b>C</b>	Conductive Polypropylene★	<b>C</b>	Conductive Polypropylene	<b>AL</b>	Aluminum	<b>BN</b>	Buna-N
	<b>H</b>	Hastelloy★	<b>P</b>	Polypropylene	<b>BN</b>	Buna-N	<b>GE</b>	Geolast
	<b>K</b>	PVDF			<b>GE</b>	Geolast®	<b>HY</b>	TPE
	<b>P</b>	Polypropylene			<b>HY</b>	TPE	<b>NE</b>	Polychloroprene Standard
	<b>S</b>	Stainless Steel★			<b>KY</b>	PVDF	<b>NW</b>	Polychloroprene Weighted
					<b>PP</b>	Polypropylene	<b>SP</b>	Santoprene
					<b>SP</b>	Santoprene®	<b>SS</b>	316 Stainless Steel
					<b>SS</b>	316 Stainless Steel	<b>TF</b>	PTFE
					<b>VT</b>	FKM Fluoroelastomer	<b>VT</b>	FKM Fluoroelastomer

★ See **ATEX Certifications**, page 4.

Diaphragm		Connections		Options	
<b>BN</b>	Buna-N	<b>FC</b>	Center Flange, DIN/ANSI	<b>00</b>	Standard
<b>GE</b>	Geolast	<b>FE</b>	End Flange, DIN/ANSI	<b>RE</b>	Remote
<b>HY</b>	TPE	<b>TB</b>	Threaded BSP	<b>SS</b>	Stroke Sensor ✖
<b>NO</b>	Polychloroprene Overmolded	<b>TN</b>	Threaded NPT	<b>UL</b>	UL-Listed
<b>SP</b>	Santoprene			✖ See <b>ATEX Certifications</b> , page 4.	
<b>TF</b>	PTFE/EPDM Two-Piece				
<b>TO</b>	PTFE/EPDM Overmolded				
<b>VT</b>	FKM Fluoroelastomer				

## ATEX Certifications

★ All *VA25AA, VA25CC, VA25HC, VA25SA, and VA25SC* pumps are certified:



✘ *Stroke Sensor is certified:*



## Warnings

The following warnings are for the setup, use, grounding, maintenance, and repair of this equipment. The exclamation point symbol alerts you to a general warning and the hazard symbol refers to procedure-specific risk. When these symbols appear in the body of this manual, refer back to these warnings. Additional, product-specific warnings may be found throughout the body of this manual where applicable.

### **WARNING**



#### **FIRE AND EXPLOSION HAZARD**

Flammable fumes, such as solvent and paint fumes, in **work area** can ignite or explode. To help prevent fire and explosion:

- Use equipment only in well ventilated area.
- Eliminate all ignition sources; such as pilot lights, cigarettes, portable electric lamps, and plastic drop cloths (potential static arc).
- Keep work area free of debris, including solvent, rags and gasoline.
- Do not plug or unplug power cords, or turn power or light switches on or off when flammable fumes are present.
- Ground all equipment in the work area. See **Grounding** instructions.
- Use only grounded hoses.
- Hold gun firmly to side of grounded pail when triggering into pail.
- If there is static sparking or you feel a shock, **stop operation immediately**. Do not use equipment until you identify and correct the problem.
- Keep a working fire extinguisher in the work area.

Static charge may build up on plastic parts during cleaning and could discharge and ignite flammable materials and gases. To help prevent fire and explosion:

- Clean plastic parts in a well ventilated area.
- Do not clean with a dry cloth.
- Do not operate electrostatic guns in equipment work area.

 **WARNING**



**EQUIPMENT MISUSE HAZARD**

Misuse can cause death or serious injury.

- Do not operate the unit when fatigued or under the influence of drugs or alcohol.
- Do not exceed the maximum working pressure or temperature rating of the lowest rated system component. See **Technical Data** in all equipment manuals.
- Use fluids and solvents that are compatible with equipment wetted parts. See **Technical Data** in all equipment manuals. Read fluid and solvent manufacturer's warnings. For complete information about your material, request MSDS from distributor or retailer.
- Do not leave the work area while equipment is energized or under pressure. Turn off all equipment and follow the **Pressure Relief Procedure** in this manual when equipment is not in use.
- Check equipment daily. Repair or replace worn or damaged parts immediately with genuine manufacturer's replacement parts only.
- Do not alter or modify equipment.
- Use equipment only for its intended purpose. Call your distributor for information.
- Route hoses and cables away from traffic areas, sharp edges, moving parts, and hot surfaces.
- Do not kink or over bend hoses or use hoses to pull equipment.
- Keep children and animals away from work area.
- Comply with all applicable safety regulations.



**PRESSURIZED EQUIPMENT HAZARD**

Fluid from the gun/dispense valve, leaks, or ruptured components can splash in the eyes or on skin and cause serious injury.

- Follow **Pressure Relief Procedure** in this manual, when you stop spraying and before cleaning, checking, or servicing equipment.
- Tighten all fluid connections before operating the equipment.
- Check hoses, tubes, and couplings daily. Replace worn or damaged parts immediately.



**THERMAL EXPANSION HAZARD**

Fluids subjected to heat in confined spaces, including hoses, can create a rapid rise in pressure due to the thermal expansion. Over-pressurization can result in equipment rupture and serious injury.



- Open a valve to relieve the fluid expansion during heating.
- Replace hoses proactively at regular intervals based on your operating conditions.



## WARNING



### PRESSURIZED ALUMINUM PARTS HAZARD

Use of fluids that are incompatible with aluminum in pressurized equipment can cause serious chemical reaction and equipment rupture. Failure to follow this warning can result in death, serious injury, or property damage.

- Do not use 1,1,1-trichloroethane, methylene chloride, other halogenated hydrocarbon solvents or fluids containing such solvents.
- Many other fluids may contain chemicals that can react with aluminum. Contact your material supplier for compatibility.



### PLASTIC PARTS CLEANING SOLVENT HAZARD

Use only compatible water-based solvents to clean plastic structural or pressure-containing parts. Many solvents can degrade plastic parts and cause them to fail, which could cause serious injury or property damage. See **Technical Data** in this and all other equipment instruction manuals. Read fluid and solvent manufacturer's warnings.



### TOXIC FLUID OR FUMES HAZARD

Toxic fluids or fumes can cause serious injury or death if splashed in the eyes or on skin, inhaled, or swallowed.

- Read MSDS's to know the specific hazards of the fluids you are using.
- Route exhaust away from work area. If diaphragm ruptures, fluid may be exhausted with air.
- Store hazardous fluid in approved containers, and dispose of it according to applicable guidelines.
- Always wear impervious gloves when spraying or cleaning equipment.



### BURN HAZARD

Equipment surfaces and fluid that's heated can become very hot during operation. To avoid severe burns:

- Do not touch hot fluid or equipment.
- Wait until equipment/fluid has cooled completely.



### PERSONAL PROTECTIVE EQUIPMENT

You must wear appropriate protective equipment when operating, servicing, or when in the operating area of the equipment to help protect you from serious injury, including eye injury, inhalation of toxic fumes, burns, and hearing loss. This equipment includes but is not limited to:

- Clothing and respirator as recommended by the fluid and solvent manufacturer
- Protective eyewear, gloves, and hearing protection

## Installation

The Typical Installations shown in FIG. 4 and FIG. 5 are only guides for selecting and installing system components. Contact your distributor for assistance in planning a system to suit your needs.

## Tighten Fasteners Before Setup

Before using the pump for the first time, check and retorque all external fasteners. Follow **Torque Instructions**, page 17.

## Mounting



- The pump exhaust air may contain contaminants. Ventilate to a remote area. See **Air Exhaust Ventilation** on page 9.
- Never move or lift a pump under pressure. If dropped, the fluid section may rupture. Always follow the **Pressure Relief Procedure** on page 15 before moving or lifting the pump.

1. For wall mounting, order Kit 859.0107.
2. Be sure the mounting surface can support the weight of the pump, hoses, and accessories, as well as the stress caused during operation.
3. For all mountings, be sure the pump is bolted directly to the mounting surface.
4. For ease of operation and service, mount the pump so air valve, air inlet, fluid inlet and fluid outlet ports are easily accessible.
5. Rubber Foot Mounting Kit 819.4333 is available to reduce noise and vibration during operation.

## Grounding

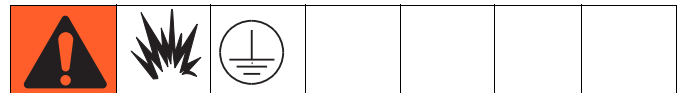

The equipment must be grounded. Grounding reduces the risk of static and electric shock by providing an escape wire for the electrical current due to static build up or in the event of a short circuit.

**Pump:** See FIG. 1. Loosen the grounding screw (GS). Insert one end of a 12 ga. minimum ground wire (R) behind the grounding screw and tighten the screw securely. Connect the clamp end of the ground wire to a true earth ground. A ground wire and clamp, Part 819.0157, is available.

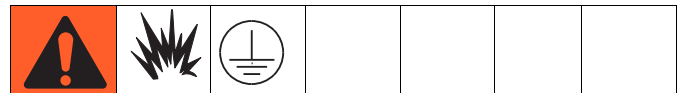

**Polypropylene and PVDF:** Only aluminum, conductive polypropylene, hastelloy, and stainless steel pumps have a ground screw. Standard polypropylene and PVDF pumps are **not** conductive. **Never** use a non-conductive polypropylene or PVDF pump with non-conductive flammable fluids. Follow your local fire codes. When pumping conductive flammable fluids, **always** ground the entire fluid system as described.

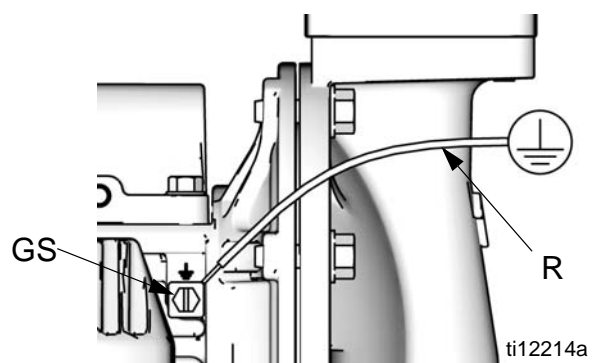

FIG. 1. Grounding screw and wire

**Air and fluid hoses:** Use only grounded hoses with a maximum of 500 ft (150 m) combined hose length to ensure grounding continuity.

**Air compressor:** Follow manufacturer's recommendations.

**Fluid supply container:** Follow local code.



**Solvent pails used when flushing:** Follow local code. Use only conductive metal pails, placed on a grounded surface. Do not place the pail on a nonconductive surface, such as paper or cardboard, which interrupts grounding continuity.

Check your system electrical continuity after the initial installation, and then set up a regular schedule for checking continuity to be sure proper grounding is maintained.

## Air Line

See FIG. 4 and FIG. 5, pages 11 and 12.

1. Install an air filter/regulator assembly (C) to control the fluid pressure and remove harmful dirt and moisture from the compressed air supply. The fluid stall pressure will be the same as the setting of the air regulator.
2. Locate a bleed-type master air valve (B) close to the pump and use it to relieve trapped air. Be sure the valve is easily accessible from the pump and located downstream from the regulator.

						
Trapped air can cause the pump to cycle unexpectedly, which could result in serious injury from splashing.						

3. Locate another master air valve (E) upstream from all air line accessories and use it to isolate them during cleaning and repair.
4. Install a grounded, flexible air hose (A) between the accessories and the 1/2 npt(f) pump air inlet (D). Use a minimum 3/8 in. (10 mm) ID air hose.

## Installation of Remote Pilot Air Lines

### NOTICE

Pilot supply pressure should not exceed 25-50% of main air supply pressure. If pilot supply pressure is too high, the pump could leak air or exhaust excessive air at stall.

1. Connect an air supply line to the pump (A, FIG. 3, page 9).
2. Insert 5/32 OD tubing into the push-to-connect fitting on each pilot valve (113).
3. Connect remaining ends of tubes to external air signal.

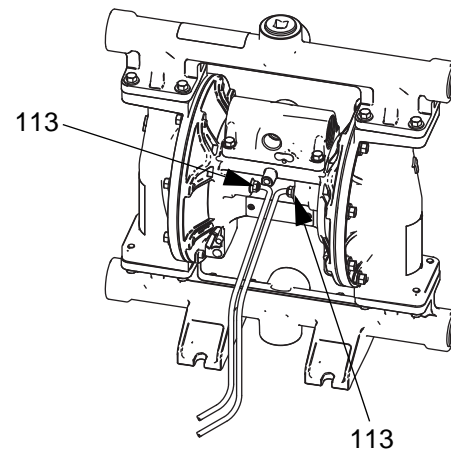

ti16894a

**FIG. 2. Connect Remote Air Control**



## Reed Switch

Stroke Sensor kits are available for use with customer-supplied fluid management or inventory tracking systems. Attach an M12, 5-pin female cable to connect the reed switch to your data monitoring system. See *Manual 859.0099*.

## Air Exhaust Ventilation

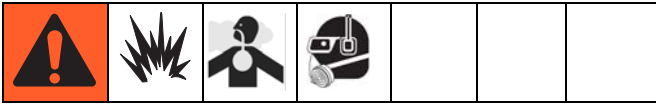

The air exhaust port is 3/4 npt(f). Do not restrict the air exhaust port. Excessive exhaust restriction can cause erratic pump operation.

To provide a remote exhaust:

1. Remove the muffler (T) from the pump air exhaust port.
2. Install a grounded air exhaust hose (U) and connect the muffler (T) to the other end of the hose. The minimum size for the air exhaust hose is 3/4 in. (19 mm) ID. If a hose longer than 15 ft (4.57 m) is required, use a larger diameter hose. Avoid sharp bends or kinks in the hose.
3. Place a container at the end of the air exhaust line to catch fluid in case a diaphragm ruptures. If the diaphragm ruptures, the fluid being pumped will exhaust with the air.

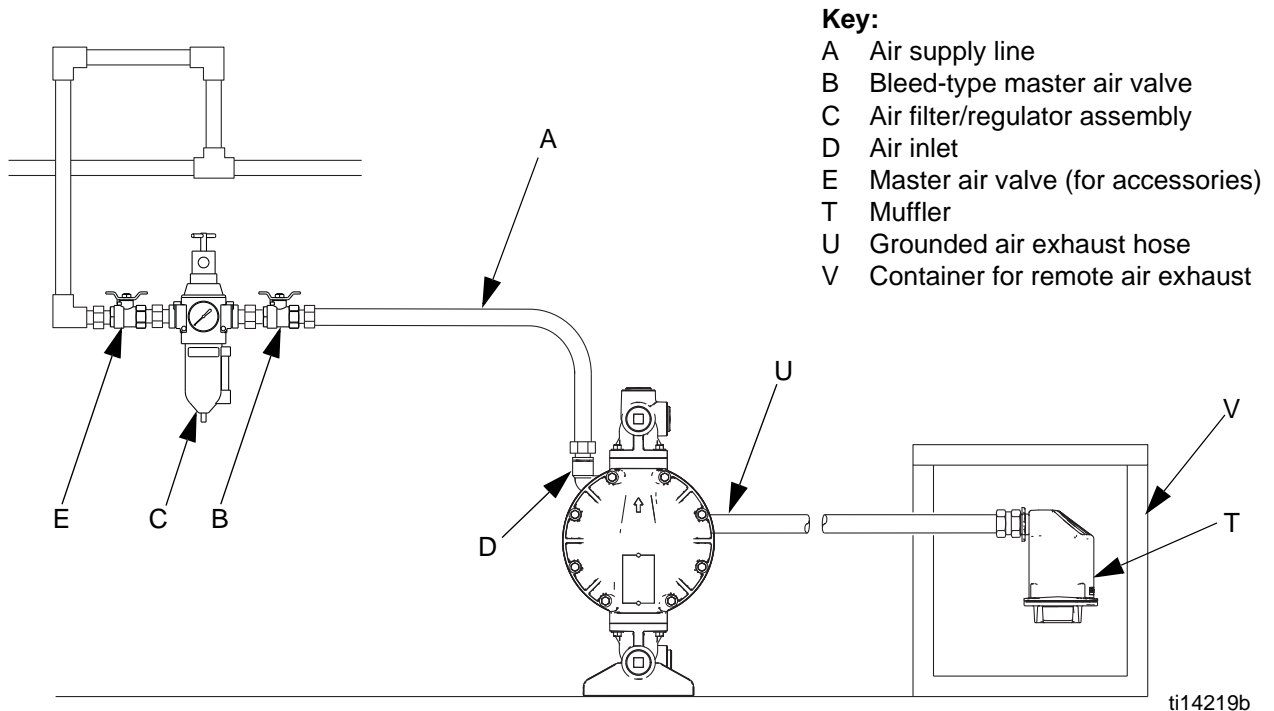

**Key:**

- A Air supply line
- B Bleed-type master air valve
- C Air filter/regulator assembly
- D Air inlet
- E Master air valve (for accessories)
- T Muffler
- U Grounded air exhaust hose
- V Container for remote air exhaust

**FIG. 3. Vent exhaust air**

ti14219b

## Fluid Supply Line

See FIG. 4 and FIG. 5, pages 11 and 12.

1. Use grounded fluid supply lines (G). See **Grounding**, page 7.
2. If the inlet fluid pressure to the pump is more than 25% of the outlet working pressure, the ball check valves will not close fast enough, resulting in inefficient pump operation. Excessive inlet fluid pressure also will shorten diaphragm life. Approximately 3 - 5 psi (0.02- 0.03 MPa, 0.21-0.34 bar) should be adequate for most materials.
3. At inlet fluid pressures greater than 15 psi (0.1 MPa, 1 bar), diaphragm life will be shortened.
4. For maximum suction lift (wet and dry), see **Technical Data**, page 23. For best results, always install the pump as close as possible to the material source.

## Fluid Outlet Line

See FIG. 4 and FIG. 5, pages 11 and 12.

1. Use grounded, flexible fluid hoses (L). See **Grounding**, page 7.
2. Install a fluid drain valve (J) near the fluid outlet.
3. Install a shutoff valve (K) in the fluid outlet line.

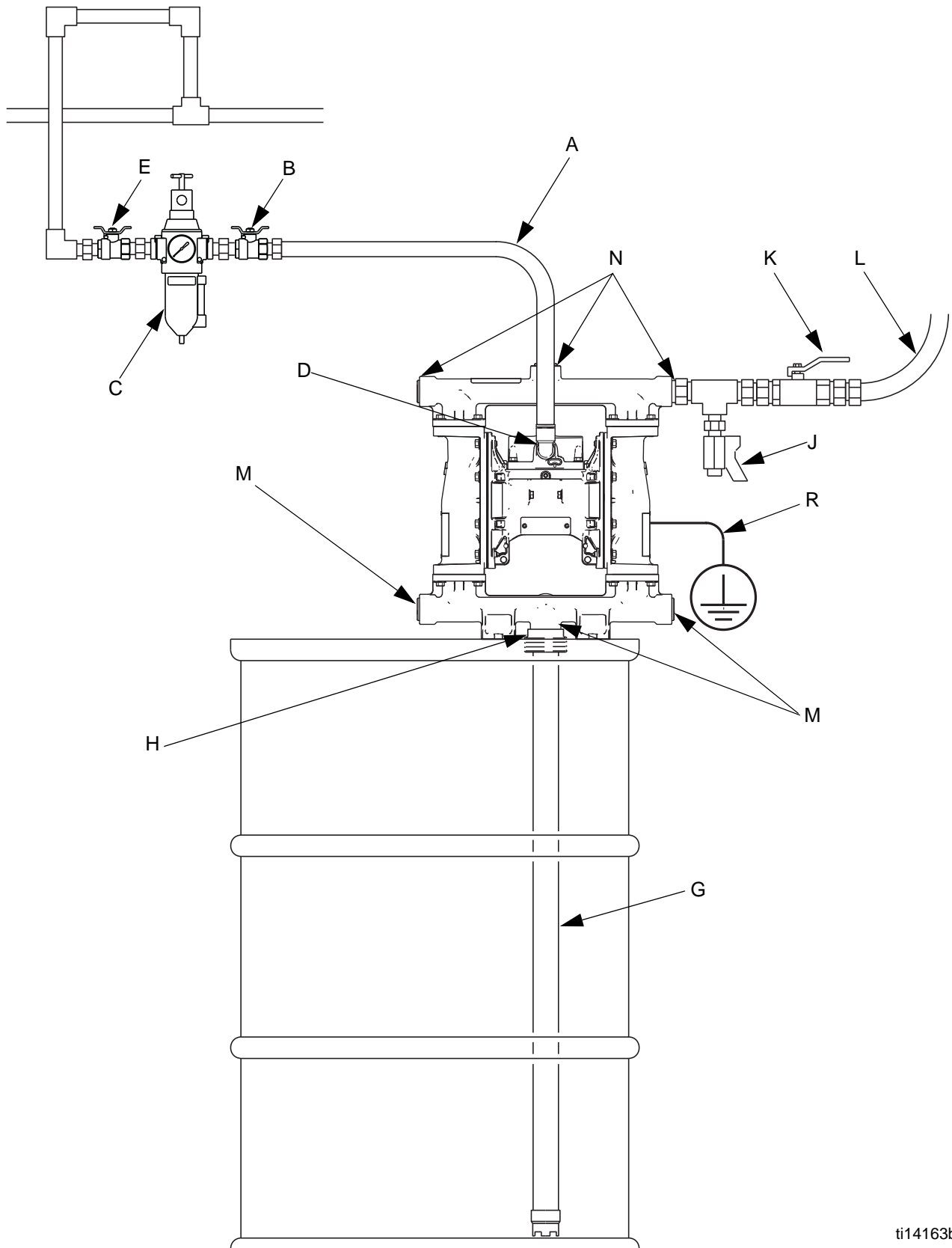

ti14163b

**FIG. 4. Typical bung-mount installation (aluminum pump shown)**

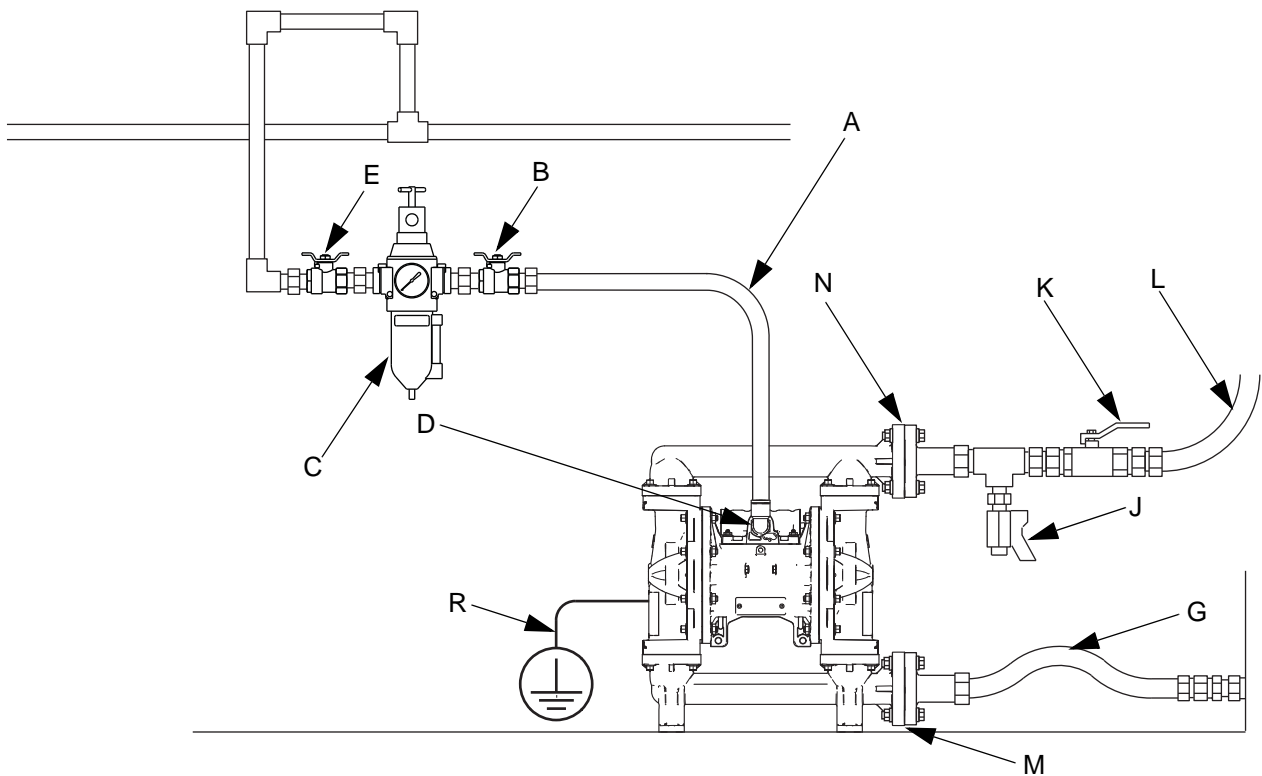

ti14164b

**FIG. 5. Typical floor-mount installation (polypropylene pump shown)**

**Key for FIG. 4 and FIG. 5:**

- A Air supply line
- B Bleed-type master air valve (required for pump)
- C Air filter/regulator assembly
- D Air inlet
- E Master air valve (for accessories)
- G Grounded, flexible fluid supply line
- J Fluid drain valve (required)
- K Fluid shutoff valve
- L Grounded, flexible fluid outlet line
- M Fluid inlet (Aluminum, FIG. 4, four ports, one not visible; Plastic, FIG. 5, center or end flanges available; Hastelloy and Stainless Steel, not pictured, one port)
- N Fluid outlet (Aluminum, FIG. 4, four ports, one not visible; Plastic, FIG. 5, center or end flanges available; Hastelloy and Stainless Steel, not pictured, one port)
- R Ground wire (required for aluminum, conductive polypropylene, hastelloy, and stainless steel pumps; see page 7 for installation instructions)

## Fluid Inlet and Outlet Ports

**NOTE:** Remove and reverse the manifold(s) to change the orientation of inlet or outlet port(s). Follow **Torque Instructions** on page 17.

### Aluminum (VA25AA)

The fluid inlet and outlet manifolds each have four 1 in. npt(f) or bspt threaded ports (FIG. 4, M, N). Close off the unused ports, using the supplied plugs.

### Plastic (VA25PP, VA25CC, and VA25KP)

The fluid inlet and outlet manifolds each have a 1 in. raised face ANSI/DIN flange (FIG. 5, M, N) in either a center or end location. Connect 1 in. standard flanged plastic pipe to the pump. See FIG. 6.

Standard pipe flange kits are available in polypropylene (819.6885), stainless steel (819.6886), and PVDF (819.6887). These kits include:

- the pipe flange
- a PTFE gasket
- four 1/2 in. bolts, spring lock washers, flat washers and nuts.

Be sure to lubricate the threads of the bolts and torque to 10-15 ft-lb (14-20 N•m). Follow the bolt tightening sequence and **do not over-torque**.

### Hastelloy (VA25HC) or Stainless Steel (VA25SA, VA25SC)

The fluid inlet and outlet manifolds each have one 1 in. npt (f) or bspt threaded port.

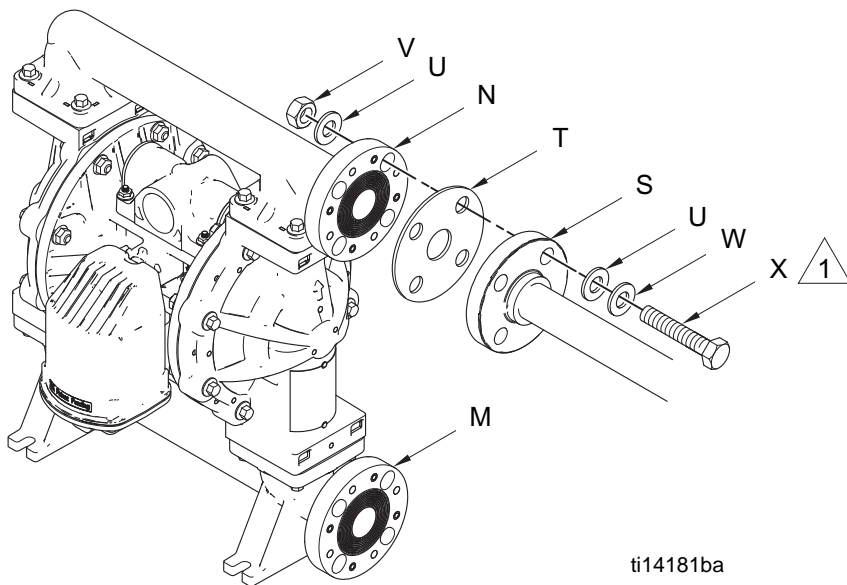

#### Bolt tightening sequence

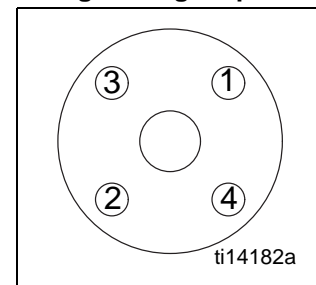

#### Key:

- M 1 in. fluid inlet flange
- N 1 in. fluid outlet flange
- S 1 in. standard pipe flange
- T PTFE gasket
- U Flat washer
- V Nut
- W Lock washer
- X Bolt

 Torque to 10-15 ft-lb (14-20 N•m). Do not over-torque.

**FIG. 6. Flange connections (plastic pumps only, VA25PP, VA25CC, and VA25KP models)**

## Fluid Pressure Relief Valve



Some systems may require installation of a pressure relief valve at the pump outlet to prevent overpressurization and rupture of the pump or hose.

Thermal expansion of fluid in the outlet line can cause overpressurization. Thermal expansion can occur when using long fluid lines exposed to sunlight or ambient heat, or when pumping from a cool to a warm area (for example, from an underground tank).

Overpressurization also can occur if the pump is used to feed fluid to a piston pump, and the intake valve of the piston pump does not close, causing fluid to back up in the outlet line.

FIG. 7 shows Fluid Pressure Relief Kit 819.6479 for aluminum pumps. Use Fluid Pressure Relief Kit 819.0159, not shown, for plastic pumps.

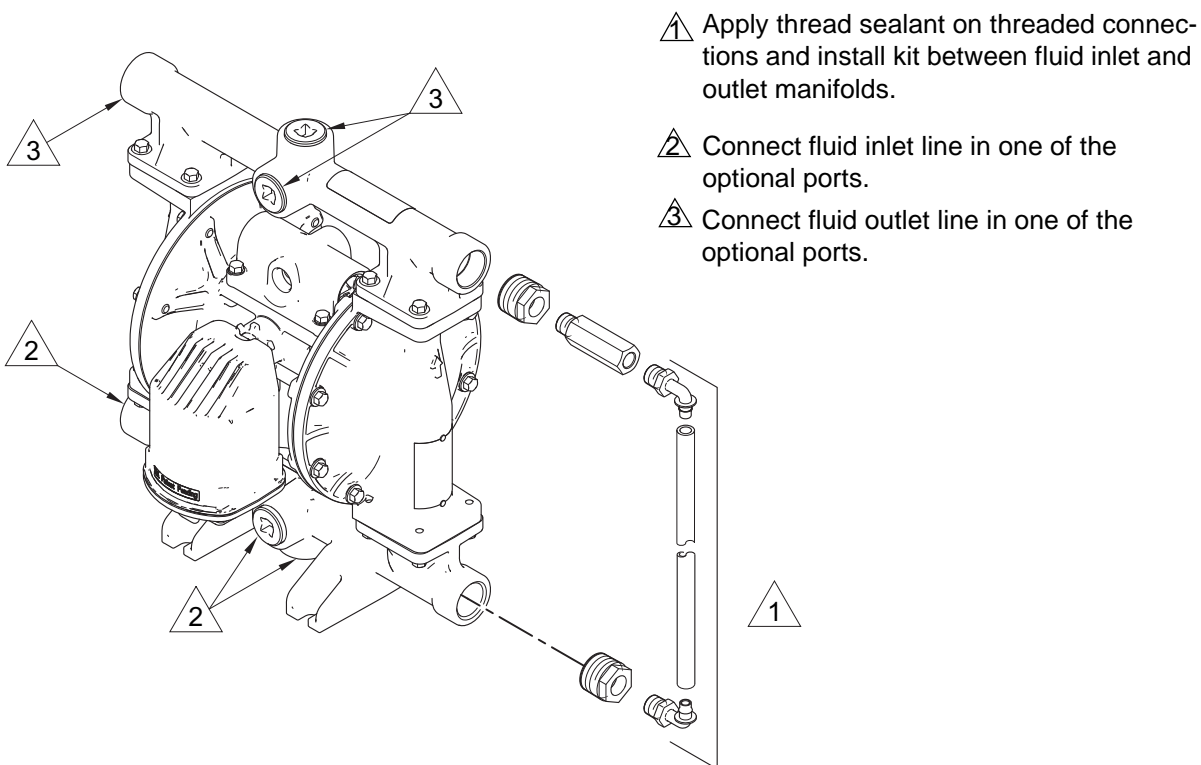





ti14214b

**Fig. 7. Fluid pressure relief kit (Aluminum pumps only, VA25AA models)**

# Operation

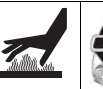
## Pressure Relief Procedure

						
<p>Trapped air can cause the pump to cycle unexpectedly, which could result in serious injury from splashing.</p>						

1. Shut off the air supply to the pump.
2. Open the dispensing valve, if used.
3. Open the fluid drain valve to relieve fluid pressure. Have a container ready to catch the drainage.

## Flush the Pump Before First Use

The pump was tested in water. If water could contaminate the fluid you are pumping, flush the pump thoroughly with a compatible solvent. See **Tighten Threaded Connections**, page 16.

## Tighten Fasteners Before Setup

Before using the pump for the first time, check and retorque all external fasteners. Follow **Torque Instructions**, page 17. After the first day of operation, retorque the fasteners.

## Starting and Adjusting the Pump

1. Be sure the pump is properly grounded. Refer to **Grounding** on page 7.
2. Check fittings to be sure they are tight. Use a compatible liquid thread sealant on male threads. Tighten fluid inlet and outlet fittings securely.
3. Place the suction tube (if used) in fluid to be pumped.

**NOTE:** If fluid inlet pressure to the pump is more than 25% of outlet working pressure, the ball check valves will not close fast enough, resulting in inefficient pump operation.

4. Place the end of the fluid hose into an appropriate container.
5. Close the fluid drain valve.
6. Back out the air regulator knob, and open all bleed-type master air valves.
7. If the fluid hose has a dispensing device, hold it open.
8. Slowly increase air pressure with the air regulator until the pump starts to cycle. Allow the pump to cycle slowly until all air is pushed out of the lines and the pump is primed.

**NOTE:** Use lowest possible air pressure to prime, just enough to cycle the pump. If the pump does not prime as expected, turn air pressure **DOWN**.

<b>NOTICE</b>
<p><b>When replacing old models of VA 25:</b> The new VA 25 operates more efficiently than did the old models. <b>Reduce</b> air inlet pressure by approximately <b>20 percent</b> to maintain an equivalent fluid output.</p>

9. If you are flushing, run the pump long enough to thoroughly clean the pump and hoses.
10. Close the dispensing valve, if used.
11. Close the bleed-type master air valve.

## Pump Shutdown



At the end of the work shift and before you check, adjust, clean or repair the system, follow **Pressure Relief Procedure**, page 15.

## Maintenance

### Maintenance Schedule

Establish a preventive maintenance schedule, based on the pump's service history. Scheduled maintenance is especially important to prevent spills or leakage due to diaphragm failure.

### Lubrication

The pump is lubricated at the factory. It is designed to require no further lubrication for the life of the pump.

### Tighten Threaded Connections

Before each use, check all hoses for wear or damage and replace as necessary. Check to be sure all threaded connections are tight and leak-free. Check fasteners. Tighten or retorque as necessary. Although pump use varies, a general guideline is to retorque fasteners every two months. See **Torque Instructions**, page 17.

## Flushing and Storage



- Flush before fluid can dry in the equipment, at the end of the day, before storing, and before repairing equipment.
- Flush at the lowest pressure possible. Check connectors for leaks and tighten as necessary.
- Flush with a fluid that is compatible with the fluid being dispensed and the equipment wetted parts.

Flush the pump often enough to prevent the fluid you are pumping from drying or freezing in the pump and damaging it. Use a compatible solvent.

Always flush the pump and relieve the pressure before storing it for any length of time.



## Torque Instructions

**NOTE:** Fluid cover and manifold fasteners have a thread-locking adhesive patch applied to the threads. If this patch is excessively worn, the fasteners may loosen during operation. Replace screws with new ones or apply medium-strength (blue) Loctite or equivalent to the threads.

If fluid cover or manifold fasteners have been loosened, it is important to torque them using the following procedure to improve sealing.

**NOTE:** Always completely torque fluid covers before torquing manifolds.

Start all fluid cover screws a few turns. Then turn down each screw just until head contacts cover. Then turn each screw by 1/2 turn or less working in a crisscross pattern to specified torque. Repeat for manifolds.

**Fluid cover and manifold fasteners:**  
90 in-lb (10.2 N•m)

Retorque the air valve fasteners (V) in a crisscross pattern to specified torque.

**Plastic center sections:** 55 in-lb (6.2 N•m)  
**Metal center sections:** 80 in-lb (9.0 N•m)

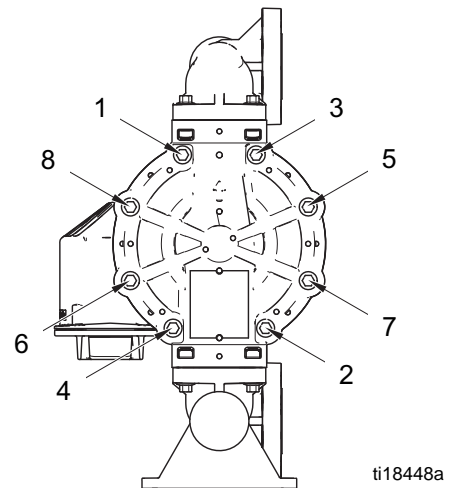

ti18448a

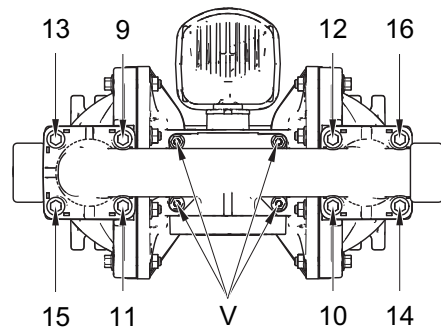

ti18449a

**FIG. 8. Torque sequence**

# Dimensions and Mounting

## Aluminum (VA25AA)

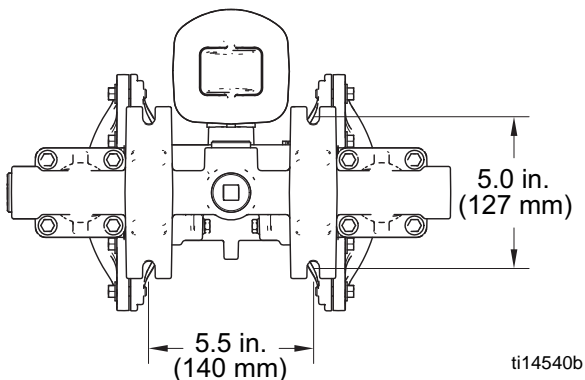
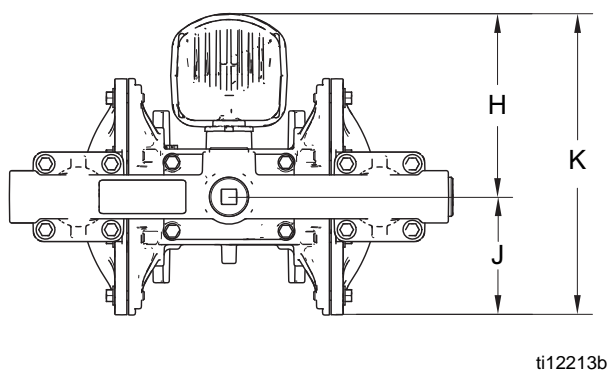
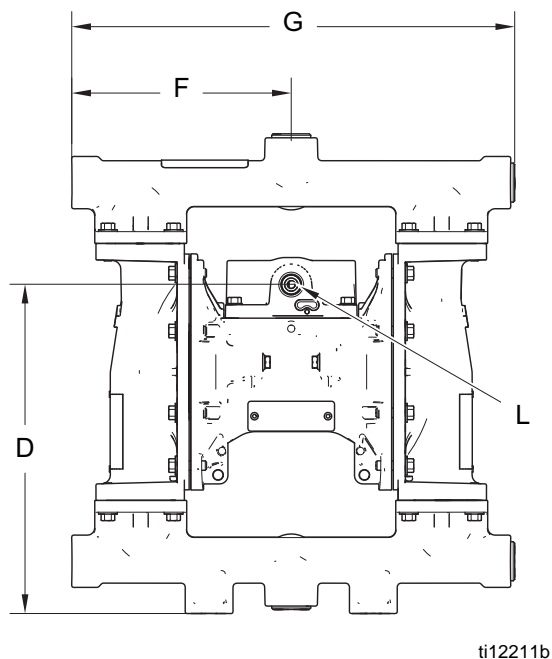
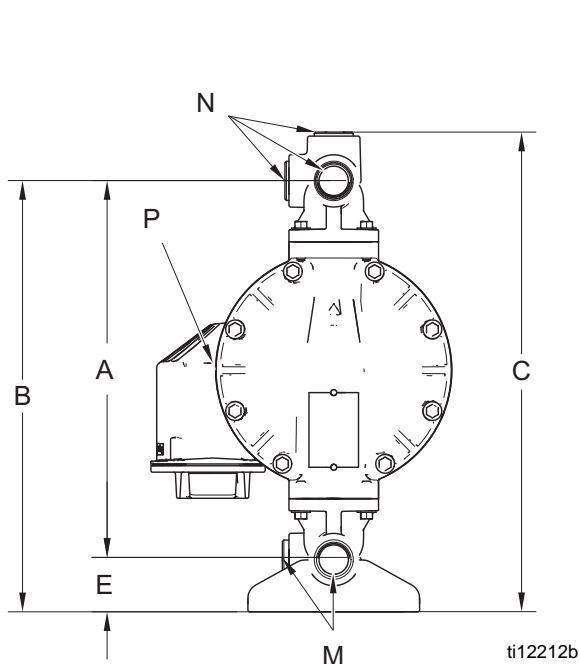

- A** ..... 12.7 in. (323 mm)
- B** ..... 14.4 in. (366 mm)
- C** ..... 15.9 in. (404 mm)
- D** ..... 10.9 in. (277 mm)
- E**..... 1.8 in. (46 mm)
- F**..... 7.3 in. (185 mm)
- G** ..... 14.7 in. (373 mm)
- H** ..... 6.2 in. (158 mm)

- J** ..... 3.9 in. (99 mm)
- K**..... 10.2 in. (258 mm)
- L** ..... 1/2 npt(f) air inlet
- M** .... 1 in. npt(f) or 1 in. bspt fluid inlet ports (4)
- N**..... 1 in. npt(f) or 1 in. bspt fluid outlet ports (4)
- P**..... 3/4 npt(f) air exhaust port

**Polypropylene (VA25PP), Conductive Polypropylene (VA25CC), and PVDF (VA25KP), Center Flange**

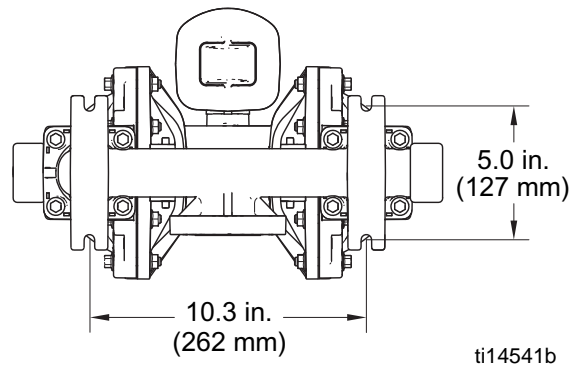
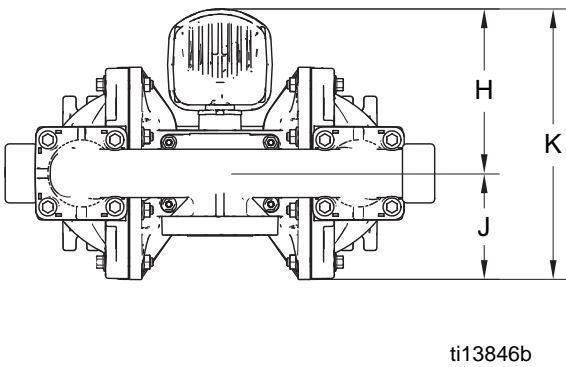
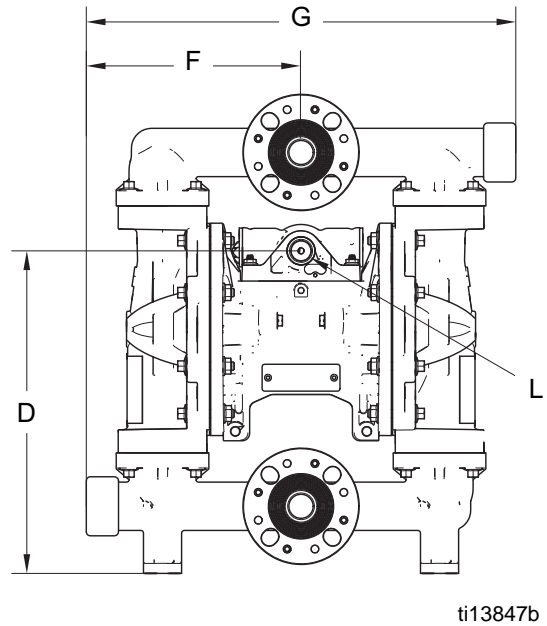
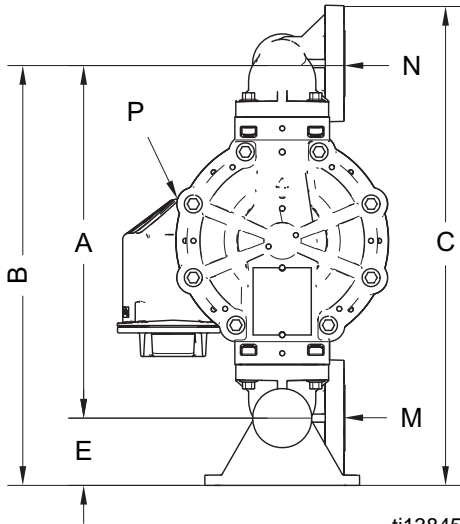

- A**..... 13.2 in. (335 mm)
- B**..... 15.7 in. (399 mm)
- C**..... 17.8 in. (452 mm)
- D**..... 12.0 in. (305 mm)
- E**..... 2.5 in. (63.5 mm)
- F**..... 8.0 in. (203 mm)
- G** .... 16.0 in. (406 mm)

- H**..... 6.2 in. (158 mm)
- J** .... 3.9 in. (99 mm)
- K**..... 10.2 in. (258 mm)
- L** .... 1/2 npt(f) air inlet
- M** .... 1 in. ANSI/DIN flange
- N**..... 1 in. ANSI/DIN flange
- P**..... 3/4 npt(f) air exhaust port

## Polypropylene (VA25PP), Conductive Polypropylene (VA25CC), and PVDF (VA25KP), End Flange

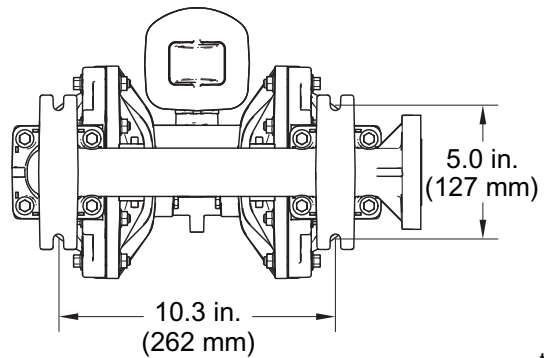
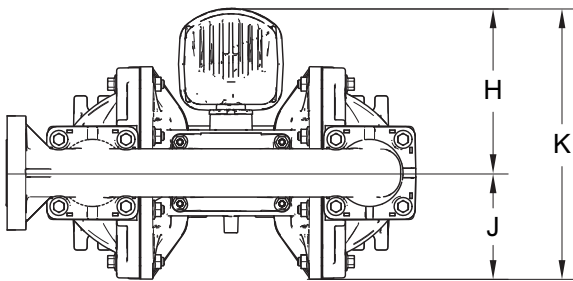
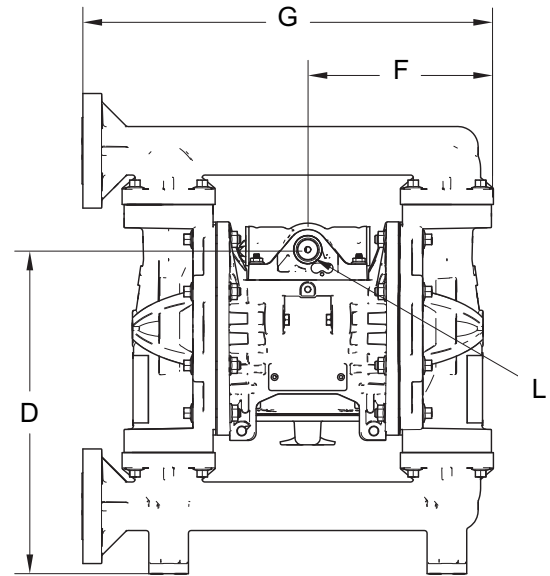
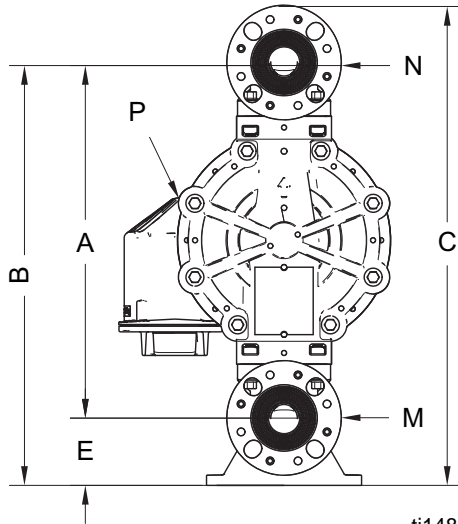

- A** ..... 13.2 in. (335 mm)
- B** ..... 15.7 in. (399 mm)
- C** ..... 17.8 in. (452 mm)
- D** ..... 12.0 in. (305 mm)
- E** ..... 2.5 in. (63.5 mm)
- F** ..... 8.0 in. (203 mm)
- G** ..... 15.2 in. (386 mm)

- H** ..... 6.2 in. (158 mm)
- J** ..... 3.9 in. (99 mm)
- K** ..... 10.2 in. (258 mm)
- L** ..... 1/2 npt(f) air inlet
- M** ..... 1 in. ANSI/DIN flange
- N** ..... 1 in. ANSI/DIN flange
- P** ..... 3/4 npt(f) air exhaust port

**Hastelloy (VA25HC) and Stainless Steel (VA25SA, VA25SC, and VA25SP)**

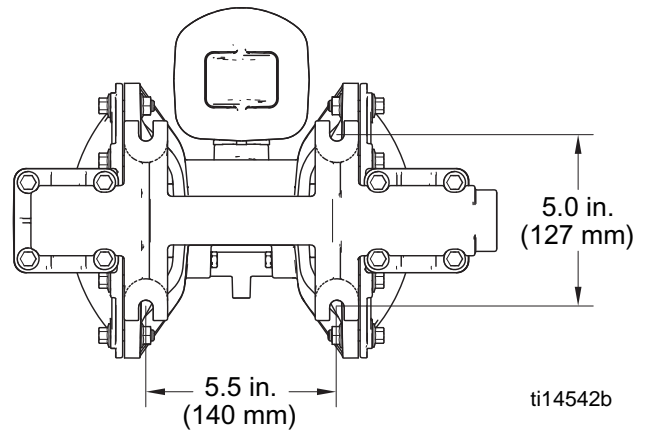
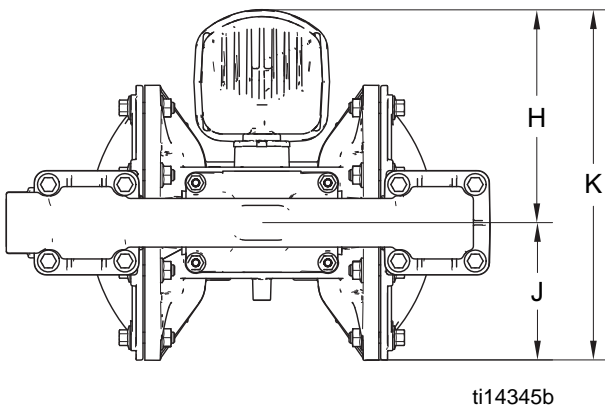
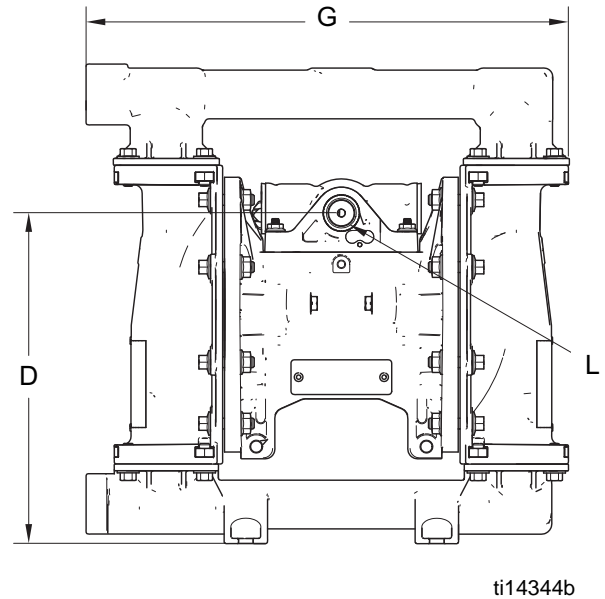
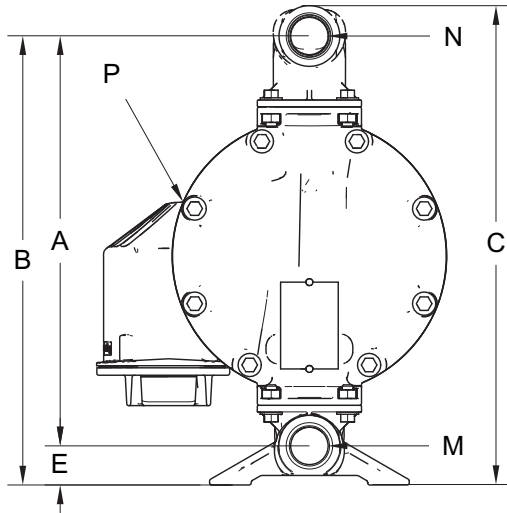

- A**..... 11.8 in. (300 mm)
- B**..... 12.9 in. (328 mm)
- C**..... 13.7 in. (348 mm)
- D**..... 9.5 in. (241 mm)
- E**..... 1.1 in. (28 mm)
- G** .... 13.9 in. (353 mm)
- H**..... 6.2 in. (158 mm)

- J** .... 4.0 in. (102 mm)
- K**..... 10.2 in. (258 mm)
- L** .... 1/2 npt(f) air inlet
- M** ... 1 in. npt(f) or 1 in. bspt fluid inlet ports (4)
- N**..... 1 in. npt(f) or 1 in. bspt fluid outlet ports (4)
- P**..... 3/4 npt(f) air exhaust port

## Performance Charts

**Test Conditions:** Pump tested in water with inlet submerged.

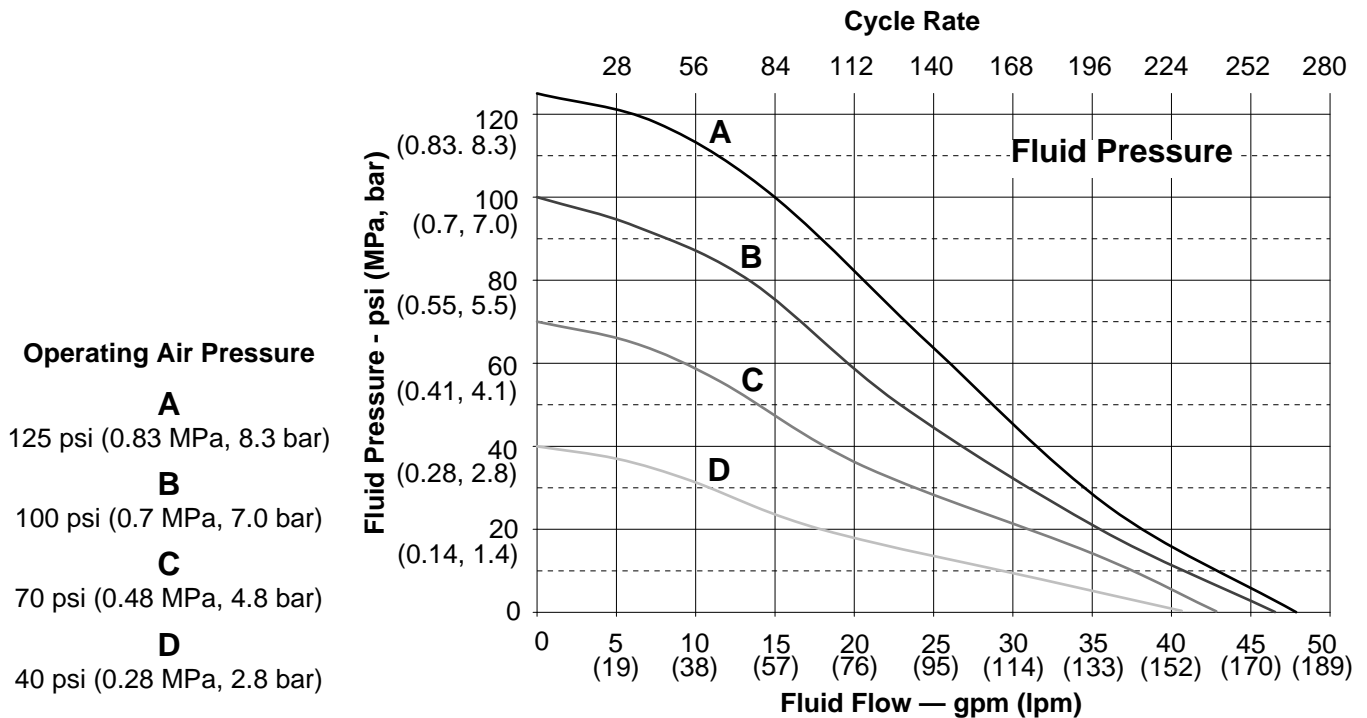

### How to Read the Charts

1. Locate fluid flow rate along bottom of chart.
2. Follow vertical line up to intersection with selected operating air pressure curve.
3. Follow left to scale to read **fluid outlet pressure** (top chart) or **air consumption** (bottom chart).

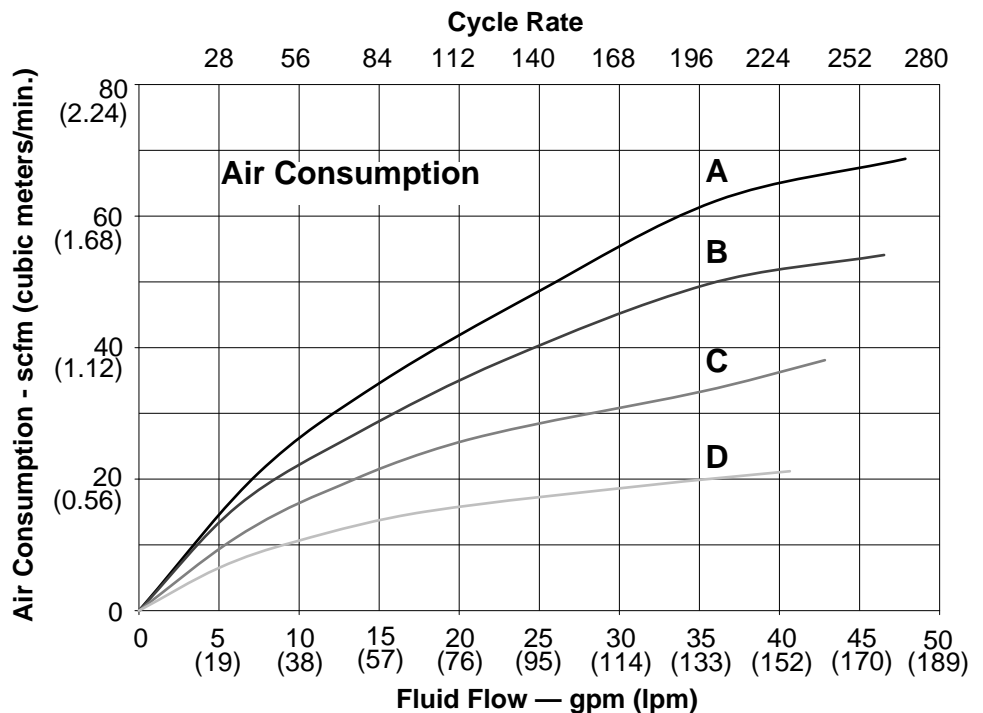

# Technical Data

Maximum fluid working pressure . . . . .	125 psi (0.86 MPa, 8.6 bar)
Air pressure operating range . . . . .	20-125 psi (0.14-0.86 MPa, 1.4-8.6 bar)
Fluid displacement per cycle . . . . .	0.17 gal. (0.64 liters)
Air consumption at 70 psi (0.48 MPa, 4.8 bar), 20 gpm (76 lpm) . . . . .	25 scfm
Maximum values with water as media under submerged inlet conditions at ambient temperature:	
Maximum air consumption . . . . .	67 scfm
Maximum free-flow delivery . . . . .	50 gpm (189 lpm)
Maximum pump speed . . . . .	280 cpm
Maximum suction lift . . . . .	16 ft (4.9 m) dry, 29 ft (8.8 m) wet
Maximum size pumpable solids . . . . .	1/8 in. (3.2 mm)
Recommended cycle rate for continuous use . . . . .	93 - 140 cpm
Recommended cycle rate for circulation systems . . . . .	20 cpm
Sound Power*	
at 70 psi (0.48 MPa, 4.8 bar) and 50 cpm . . . . .	78 dBA
at 100 psi (0.7 MPa, 7.0 bar) and full flow . . . . .	90 dBA
Sound Pressure**	
at 70 psi (0.48 MPa, 4.8 bar) and 50 cpm . . . . .	84 dBA
at 100 psi (0.7 MPa, 7.0 bar) and full flow . . . . .	96 dBA
Operating temperature range . . . . .	see page 25
Air inlet size . . . . .	1/2 npt(f)
Fluid inlet size	
Aluminum (VA25AA) . . . . .	1 in. npt(f) or 1 in. bspt
Plastic (VA25PP, VA25CC, and VA25KP) . . . . .	1 in. raised face ANSI/DIN flange
Hastelloy (VA25HC) and Stainless Steel (VA25SA, VA25SC, and VA25SP) . . . . .	1 in. npt(f) or 1 in. bspt
Fluid outlet size	
Aluminum (VA25AA) . . . . .	1 in. npt(f) or 1 in. bspt
Plastic (VA25PP, VA25CC, and VA25KP) . . . . .	1 in. raised face ANSI/DIN flange
Hastelloy (VA25HC) and Stainless Steel (VA25SA, VA25SC, and VA25SP) . . . . .	1 in. npt(f) or 1 in. bspt
Weight	
Aluminum (VA25AA) . . . . .	23 lb. (10.5 kg)
Hastelloy (VA25HC) . . . . .	41 lb. (18.6 kg)
Polypropylene and Conductive Polypropylene (VA25PP and VA25CC) . . . . .	18 lb. (8.2 kg)
PVDF(VA25KP) . . . . .	26 lb (11.8 kg)
Stainless Steel	
with conductive polypropylene center (VA25SC) . . . . .	36.3 lb. (16.5 kg)
with polypropylene center (VA25SP) . . . . .	37.3 lb. (16.9 kg)
with aluminum center (VA25SA) . . . . .	41.4 lb. (18.8 kg)

Wetted parts include material(s) chosen for seat, ball, and diaphragm options, **plus** the pump's material of construction

VA25AA	Aluminum
VA25HC	Hastelloy
VA25PP and VA25CC	Polypropylene
VA25KP	PVDF
VA25SA, VA25SC, and VA25SP	Stainless Steel

Non-wetted external parts

Aluminum (VA25AA)	aluminum, coated carbon steel
Hastelloy (VA25HC)	hastelloy, stainless steel, polypropylene or aluminum (if used in center section)
Plastic (VA25PP, VA25CC, and VA25KP)	stainless steel, polypropylene
Stainless Steel (VA25SA, VA25SC, and VA25SP)	stainless steel, polypropylene or aluminum (if used in center section)

\* Sound power measured per ISO-9614-2.

\*\* Sound pressure was tested 3.28 ft (1 m) from equipment.

All trademarks mentioned in this manual are the property of their respective owners.



**Operating Temperature Range**

**NOTICE**

Temperature limits are based on mechanical stress only. Certain chemicals will further limit the fluid temperature range. Stay within the temperature range of the most-restricted wetted component. Operating at a fluid temperature that is too high or too low for the components of your pump may cause equipment damage.

Diaphragm/Ball/Seat Material	Fluid Temperature Range					
	Aluminum, Hastelloy, or Stainless Steel Pumps		Polypropylene or Conductive Polypropylene Pumps		PVDF Pumps	
	Fahrenheit	Celsius	Fahrenheit	Celsius	Fahrenheit	Celsius
Acetal (AC)	10° to 180°F	-12° to 82°C	32° to 150°F	0° to 66°C	10° to 180°F	-12° to 82°C
Buna-N (BN)	10° to 180°F	-12° to 82°C	32° to 150°F	0° to 66°C	10° to 180°F	-12° to 82°C
FKM Fluoroelastomer (VT)*	-40° to 275°F	-40° to 135°C	32° to 150°F	0° to 66°C	10° to 225°F	-12° to 107°C
Geolast® (GE)	-40° to 150°F	-40° to 66°C	32° to 150°F	0° to 66°C	10° to 150°F	-12° to 66°C
Polychloroprene over-molded diaphragm (NO) or Polychloroprene check balls (NE or NW)	0° to 180°F	-18° to 82°C	32° to 150°F	0° to 66°C	10° to 180°F	-12° to 82°C
Polypropylene (PP)	32° to 150°F	0° to 66°C	32° to 150°F	0° to 66°C	32° to 150°F	0° to 66°C
PTFE overmolded diaphragm (TO)	40° to 180°F	4° to 82°C	40° to 150°F	4° to 66°C	40° to 180°F	4.0° to 82°C
PTFE check balls or two-piece PTFE/EPDM diaphragm (TF)	40° to 220°F	4° to 104°C	40° to 150°F	4° to 66°C	40° to 220°F	4° to 104°C
PVDF (KY)	10° to 225°F	-12° to 107°C	32° to 150°F	0° to 66°C	10° to 225°F	-12° to 107°C
Santoprene® (SP)	-40° to 180°F	-40° to 82°C	32° to 150°F	0° to 66°C	10° to 180°F	-12° to 82°C
TPE (HY)	-20° to 150°F	-29° to 66°C	32° to 150°F	0° to 66°C	10° to 150°F	-12° to 66°C

\* The maximum temperature listed is based on the ATEX standard for T4 temperature classification. If you are operating in a non-explosive environment, FKM fluoroelastomer's maximum operating temperature in aluminum or stainless steel pumps is 320°F (160°C).



## EU-DECLARATION OF CONFORMITY

EU-KONFORMITEITSVERKLARING, DÉCLARATION UE DE CONFORMITÉ, EU-KONFORMITÄTSEKTLÄRUNG DICHIARAZIONE DI CONFORMITÀ UE, EU-OVERENSSTEMMELSESEKTLÆRING, ΔΗΛΩΣΗ ΣΥΜΜΟΡΦΩΣΗΣ ΕΕ, DECLARAÇÃO UE DE CONFORMIDADE, DECLARACIÓN UE DE CONFORMIDAD, EU-VAATIMUSTENMUKAISUUSVAKUUTUS, EU-FÖRSÄKRAN OM ÖVERENSSTÄMMELSE, EU PROHLÁŠENÍ O SHODĚ, ELI VASTAVUSDEKLARATSIOON, EU-MEGFELELŐSÉGI NYILATKOZAT, ES ATBILSTĪBAS DEKLARĀCIJA, ES ATITIKTIES DEKLARĀCIJA DEKLARACJA ZGODNOŚCI UE, DIKJARAZZJONI TA' KONFORMITÀ TAL-UE, EU IZJAVA O SUKLADNOSTI, EU VYHLÁSENIE O ZHODE, ЕС ДЕКЛАРАЦИЯ ЗА СЪОТВЕТСТВИЕ, DECLARAȚIA UE DE CONFORMITATE

### Model

Modèle, Modell, Modello, Μοντέλο, Modelo, Malli, Mudel, Modelis, Mudell, Модел, Samhail

VERDERAIR VA 25

### Part

Bestelnr., Type, Teil, Codice, Del, Μέρος, Peça, Referencia, Osa, Součást, Részegység, Dajla, Dalis, Część, Taqsim, Část, Част, Páirt, Parte

850.0073\*, 850.0074\*, 850.0078, 850.0081, 850.0082\*–850.0084\*,  
850.0191–850.0194, 850.0248, 850.0255, 850.0265, 850.0283, 850.0331,  
850.0371\*, 850.0382, 850.0419, 850.0429, 850.0430, 850.0535, 850.0545,  
850.0563, 850.0569, 850.0662, 850.0780, 850.2680, 850.2855, 850.2925\*,  
850.2935\*, 850.2945\*, 850.3100\*, 850.3122\*, 850.3128\*, 850.3134\*, 850.3282\*,  
850.3380\*, 850.3402\*, 850.3414\*, 850.6346, 850.6976\*, 850.6980–850.6982,  
850.7007, 850.7011\*, 850.7012\*, 850.7048\*, 850.7049\*, 850.8000\*–850.8007\*,  
850.8008–850.8014, 850.8015\*, 850.8016\*, 850.8017–850.8022, 850.8023\*,  
850.8031–850.8063, 850.8064–850.8088\*, 850.8089–850.8094, 850.8095\*,  
850.8096\*–850.8098, 850.8100\*, 850.8101, 850.8145 (\*Do not have ATEX approval)

### Complies With The EC Directives:

Voldoet aan de EG-richtlijnen, Conforme aux directives CE, Entspricht den EG-Richtlinien, Conforme alle direttive CE, Overholder EF-direktiverne, Σύμφωνα με τις Οδηγίες της ΕΚ, Em conformidade com as Directivas CE, Cuple las directivas de la CE, Täyttää EY-direktiivien vaatimukset, Uppfyller EG-direktiven, Shoda se směrniciami ES, Vastab EU direktiividele, Kielégíti az EK irányelvek követelményeit, Atitinka šias ES direktivas, Zgodność z Dyrektywami UE, Konformi mad-Direttivi tal-KE, V skladu z direktivami ES, Je v súlade so smernicami ES, Съвместимост с Директиви на ЕО, Та аg teacht le Teoracha an CE, Respectă directivele CE

#### 2006/42/EC Machinery Safety Directive

2014/34/EC ATEX Directive (Ex II 2 GD c II C T4) - Tech File stored with NB 0359

(See Part No. above for corresponding ATEX approved pumps.)

### Standards Used:

Gebruikte maatstaven, Normes respectées, Verwendete Normen, Norme applicate, Anvendte standarder, Πρότυπα που χρησιμοποιήθηκαν, Normas utilizadas, Normas aplicadas, Sovellettavat standardit, Tillämpade standarder, Použité normy, Rakendatud standardid, Alkalmazott szabványok, Izmantotie standarti, Taikyti standartai, Užyte normy, Standards Užati, Uprabljeni standardi, Použité normy, Използвани стандарти, Caighdeáin arna n-úsáid, Standarde utilizate

EN 1127-1 ISO 12100-2

EN 13463-1 ISO 9614-2

EN 13463-5

### Notified Body for Directive

Aangemelde instantie voor richtlijn, Organisme notifié pour la directive, Benannte Stelle für diese Richtlinie, Ente certificatore della direttiva, Bemyndiget organ for direktiv, Διακωνωμένο όργανο Οδηγίας, Organismo notificado relativamente à directiva, Organismo notificado de la directiva, Direktiivin mukaisesti ilmoitettu tarkastuslaitos, Anmält organ för direktivet, Úředně oznámený orgán pro směrnici, Teavitatud asutus (direktiivi järgi), Az irányelvvvel kapcsolatban értesített testület, Pilnvarotā iestāde saskaņā ar direktīvu, Apie direktīvu Informuota institūcija, Ciało powiadomione dla Dyrektywy, Korp avzat bid-Direttiva, Priglašeni organ za direktivo, Notifikovaný orgán pre smernicu, Нотифициран орган за Директива, Comhlacht ar tugadh fógra dó, Organism notificat în conformitate cu directiva

--	--	--

### Approved By:

Goedgekeurd door, Approuvé par, Genehmigt von, Approvato da, Godkendt af, Έγκριση από, Aprobado por, Aprobado por, Hyväksynyt, Intygat av, Schwälil, Kinnitanud, Jövähagyta, Apstiprināts, Patvirtino, Zatwierdzone przez, Approvat minn, Odobril, Schwäléné, Одобрено от, Faafa ag, Aprobat de

Werner Bosman  
Managing Director

16 February 2017

### VERDER BV

Leningradweg 5  
9723 TP Groningen  
NETHERLANDS

859.0086

B

This declaration of conformity is issued under the sole responsibility of the manufacturer. Deze conformiteitsverklaring wordt verstrekt onder volledige verantwoordelijkheid van de fabrikant. La présente déclaration de conformité est établie sous la seule responsabilité du fabricant. Die alleinige Verantwortung für die Ausstellung dieser Konformitätserklärung trägt der Hersteller. La presente dichiarazione di conformità è rilasciata sotto la responsabilità esclusiva del fabbricante. Denne overensstemmelseserklæring udstedes på fabrikantens ansvar. Η παρούσα δήλωση συμμόρφωσης εκδίδεται με αποκλειστική ευθύνη του κατασκευαστή. A presente declaração de conformidade é emitida sob a exclusiva responsabilidade do fabricante. La presente declaración de conformidad se expide bajo la exclusiva responsabilidad del fabricante. Tämä vaatimustenmukaisuusvakuutus on annettu valmistajan yksinomaisella vastuulla. Denna försäkran om överensstämmelse utfärdas på tillverkarens eget ansvar. Toto prohlášení o shodě se vydává na výhradní odpovědnost výrobce. Käesolev vastavusdeklaratsioon on välja antud tootja ainuvastutusel. Ezt a megfelelőségi nyilatkozatot a gyártó kizárólagos felelőssége mellett adják ki. Ši atbilstības deklarācija ir izdota vienīgi uz ražotāja atbildību. Ši atitikties deklaracija išduota tik gamintojo atsakomybe. Niniejsza deklaracja zgodności wydana zostaje na wyłączną odpowiedzialność producenta. Din id-dikjarazzjoni tal-konformità qiegħda tinhareg taħt ir-responsabbiltà unika tal-manifattur. Ta izjava o skladnosti je izdana na lastno odgovornost proizvajalca. Toto vyhlásenie o zhode sa vydáva na výhradnú zodpovednosť výrobcu. Настоящата декларация за съответствие е издадена на отговорността на производителя. Prezenta declarație de conformitate este emisă pe răspunderea exclusivă a producătorului.

## **Customer Services/Guarantee**

### **CUSTOMER SERVICES**

If you require spare parts, please contact your local distributor, providing the following details:

- Pump Model
- Type
- Serial Number, and
- Date of First Order.

### **GUARANTEE**

All VERDER pumps are warranted to the original user against defects in workmanship or materials under normal use (rental use excluded) for two years after purchase date. This warranty does not cover failure of parts or components due to normal wear, damage or failure which in the judgement of VERDER arises from misuse.

Parts determined by VERDER to be defective in material or workmanship will be repaired or replaced.

### **LIMITATION OF LIABILITY**

To the extent allowable under applicable law, VERDER's liability for consequential damages is expressly disclaimed. VERDER's liability in all events is limited and shall not exceed the purchase price.

### **WARRANTY DISCLAIMER**

VERDER has made an effort to illustrate and describe the products in the enclosed brochure accurately; however, such illustrations and descriptions are for the sole purpose of identification and do not express or imply a warranty that the products are merchantable, or fit for a particular purpose, or that the products will necessarily conform to the illustration or descriptions.

### **PRODUCT SUITABILITY**

Many regions, states and localities have codes and regulations governing the sale, construction, installation and/or use of products for certain purposes, which may vary from those in neighboring areas. While VERDER attempts to assure that its products comply with such codes, it cannot guarantee compliance, and cannot be responsible for how the product is installed or used. Before purchasing and using a product, please review the product application as well as the national and local codes and regulations, and be sure that product, installation, and use complies with them.

Original instructions. This manual contains English.  
Revision R- March 2017

**Austria**

Verder Austria  
Eitnergasse 21/Top 8  
A-1230 Wien  
AUSTRIA  
Tel: +43 1 86 51 074 0  
Fax: +43 1 86 51 076  
e-mail: office@verder.at

**Belgium**

Verder nv  
Kontichsesteenweg 17  
B-2630 Aartselaar  
BELGIUM  
Tel: +32 3 877 11 12  
Fax: +32 3 877 05 75  
e-mail: info@verder.be

**China**

Verder Shanghai Instruments and Equipment Co., Ltd  
Building 8 Fuhai Business Park No. 299  
Bisheng Road, Zhangjiang Hiteck Park  
Shanghai 201204  
CHINA  
Tel: +86 21 33932950  
Fax: +86 21 33932955  
e-mail: info@verder.cn

**Bulgaria**

Verder Bulgaria Ltd  
Vitosh department,  
Manastriski Livadi Zapad  
district,  
110 Bulgaria Blvd., 2-nd  
Floor, apt. 15-16,  
1618 - Sofia  
BULGARIA  
Tel: 0878407370  
Fax: 02 9584085  
email: office@verder.bg

**Czech Republic**

Verder s.r.o.  
Vodnanská 651/6 (vchod  
Chlumecka 15)  
198 00 Praha 9-Kyje  
CZECH REPUBLIC  
Tel: +420 261 225 386-7  
Web: <http://www.verder.cz>  
e-mail: info@verder.cz

**Denmark**

Verder A/S  
Sales Denmark  
Leningradweg 5  
NL 9723 TP Groningen  
THE NETHERLANDS  
Tel: +45 3636 4600  
e-mail: info@verder.dk

**France**

Verder France  
Parc des Bellevues,  
Rue du Gros Chêne  
F-95610 Eragny sur Oise  
FRANCE  
Tel: +33 134 64 31 11  
Fax: +33 134 64 44 50  
e-mail: verder-  
info@verder.fr

**Germany**

Verder Deutschland GmbH  
Retsch-Allee 1-5  
42781 Haan  
GERMANY  
Tel: 02104/2333-200  
Fax: 02104/2333-299  
e-mail: info@verder.de

**Hungary**

Verder Hongary Kft  
Budafoke ut 187 - 189  
HU-1117 Budapest  
HUNGARY  
Tel: 0036 1 3651140  
Fax: 0036 1 3725232  
e-mail: info@verder.hu

**India**

Verder India Pumps Pvt  
Ltd.  
Plot No-3B, D-1 Block,  
MIDC Chinchwad,  
Pune - 411019  
INDIA  
e-mail:  
Sales@verder.co.in  
[www.verder.co.in](http://www.verder.co.in)

**Italy**

Verder Italia  
Via Maestri Del lavoro, 5  
02100 Vazia, Rieti  
ITALY  
Tel: +39 07 46 229064  
e-mail: info@verder.it

**The Netherlands**

Verder BV  
Leningradweg 5  
NL 9723 TP Groningen  
THE NETHERLANDS  
Tel: +31 50 549 59 00  
Fax: +31 50 549 59 01  
e-mail: info@verder.nl

**Poland**

Verder Polska  
ul.Ligonia 8/1  
PL-40 036 Katowice  
POLAND  
Tel: +48 32 78 15 032  
Fax: +48 32 78 15 034  
e-mail: verder@verder.pl

**Romania**

Verder România  
Drumul Balta Doamnei  
no 57-61  
Sector 3  
CP 72-117  
032624 Bucuresti  
ROMANIA  
Tel: +40 21 335 45 92  
Fax: +40 21 337 33 92  
e-mail: office@verder.ro

**Slovak Republik**

Verder Slovakia s.r.o.  
Silacska 1  
SK-831 02 Bratislava  
SLOVAK REPUBLIK  
Tel: +421 2 4463 07 88  
Fax: +421 2 4445 65 78  
e-mail: info@verder.sk

**South Africa**

Verder SA  
197 Flaming Rock Avenue  
Northlands Business Park  
Newmarket Street  
ZA Northriding  
SOUTH AFRICA  
Tel: +27 11 704 7500  
Fax: +27 11 704 7515  
e-mail: info@verder.co.za

**Switzerland**

Verder Deutschland GmbH  
Sales Switzerland  
Retsch-Allee 1-5  
D-42781 Haan  
GERMANY  
Tel: +41 (0)61 331 33 13  
Fax: +41 (0)61 331 63 22  
e-mail: info@verder.ch

**United Kingdom**

Verder UK Ltd.  
Unit 3 California Drive  
Castleford, WF10 5QH  
UNITED KINGDOM  
Tel: +44 (0) 1924 221 001  
Fax: +44 (0) 1132 465 649  
e-mail: info@verder.co.uk

**United States of America**

Verder Inc.  
312 Corporate Parkway  
Suite 101  
Macon, GA 31210  
USA  
Tel: +1 877 783 7337  
Fax: +1 478 476 9867  
e-mail: sales@verder-  
us.com