

INDUSTRY PUMPS & EQUIPMENT
CATALOGUE

www.sydexpump.com

Table of contents

- **Table of content** 2
- **Company** 3
- **SYDEX markets and applications** 5
- **SYDEX product range**
 - K Range 7
 - M Range 9
 - H Range 11
 - WH Configurations 13
 - W Range 15
 - WL Range 17
 - G Range 19
 - G-Bio 21
 - E Range 23
 - FM Range 25
 - ATEX 27
 - API 676 29
 - Defender 31
 - C031 Eliminator 33
- **SYDEX at your service** 35





***Italian manufacturer of
Progressing Cavity Pumps, Conveyors and Grinders.***

Sydex is a modern, global manufacturer of progressing cavity pumps, grinders and macerators. We provide extensive expertise and knowledge throughout the world, enabling us to become totally focused on our customers' needs from manufacturing through to delivery, documentation, installation and after-sales support.

Our in-house stator manufacturing capability enables us to ensure superior quality whilst providing cost-effective, innovative solutions and reliable delivery times.



Markets and Applications.



INDUSTRY



OIL & GAS



WASTE WATER TREATMENT



MARINE



FOOD & DRINKS



BIO-PHARMACEUTICAL



BIOGAS



MINING & QUARRIES



RECYCLING & WASTE

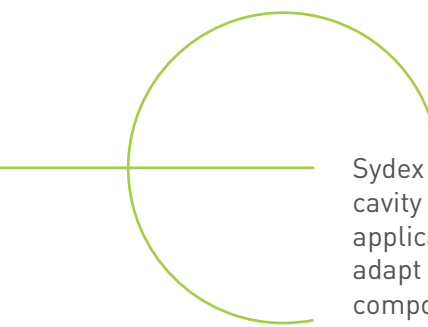

Sydex provides a wide range of positive displacement pumps including progressing cavity pumps, conveyors and grinders to meet specific requirements of a multitude of applications and markets. Thanks to its expertise and markets knowledge, Sydex can adapt its products according to the customers' constraints with a variety of materials and components.



A comprehensive range of progressing cavity pumps for viscous, abrasive, low NPSH and difficult applications.



A complete range of horizontal and vertical pumps dedicated to Oil & Gas applications including API 676 pumps.



Low flow and high pressure polymer dosing pumps, sludge PCP, high dry solids transfer pumps, belt-presses and centrifuges.



A dedicated range of progressing cavity pumps installed on marine vessels for bilge water processing and sewage treatment.



Hygienic progressing cavity pumps to meet the strictest hygiene standards for food and drink applications.



Chemical dosing and metering pumps available in a wide range of materials to suit the different bio-pharmaceutical and chemical products.



Progressing cavity pumps and macerators.



Progressing cavity pumps for transferring solids and abrasive liquids with high flowrate and high pressure.



Pumps and equipment for solids reduction and waste management.

K Range

Sludge Progressing Cavity Pumps

Discover the advantages and performances of the K range sludge progressing cavity pump dedicated to wastewater, oil & gas and marine applications.

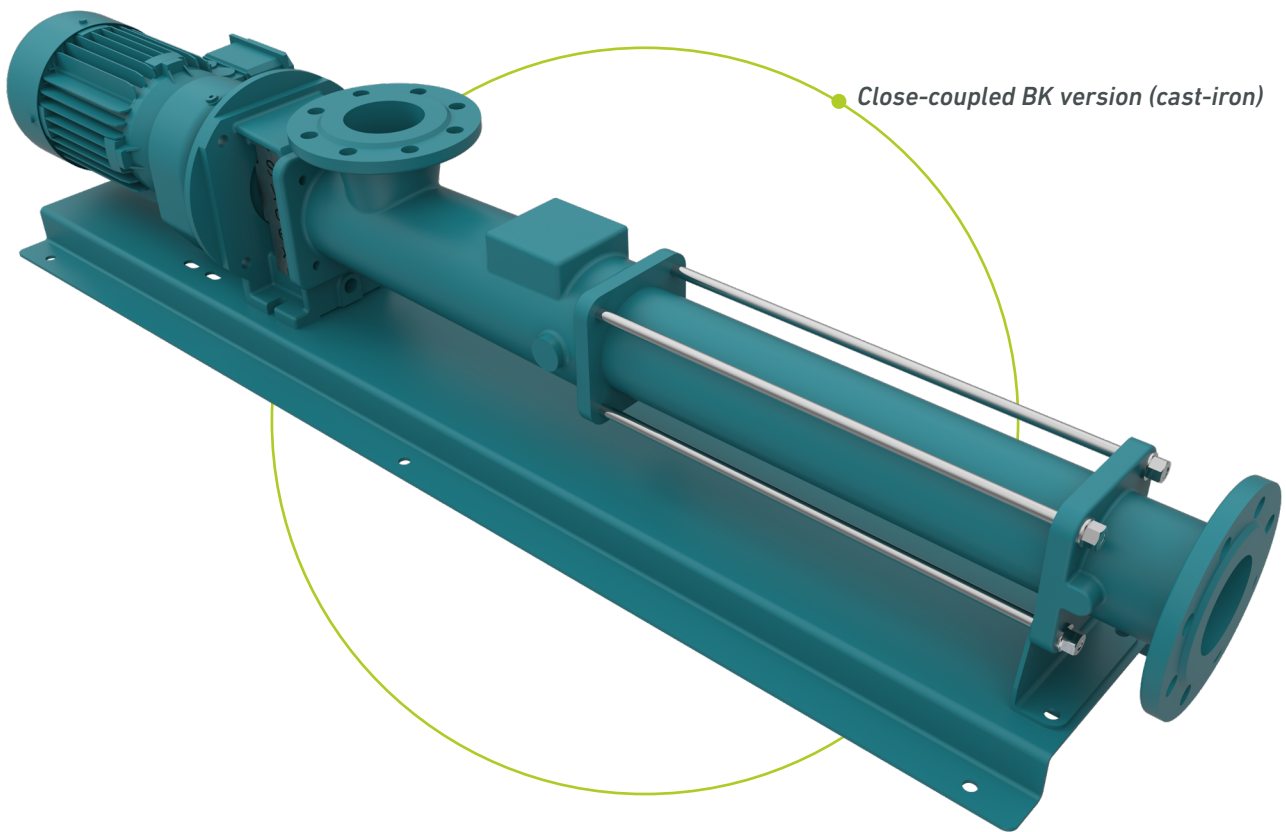

Advantages

- Robust design, clearest delivery time and best value for money in the market.
- Wide pumps range and large variety of building materials.
- Geared motor: the speed is carefully selected according to your application. We only rely on top quality manufacturer for this essential component.
- Extended connecting rod, which ensures extremely low angularity and increases significantly stator/rotor and seal life.
- Easy maintenance through the fitted ports.
- Steady and constant flow.
- Reversible flow.
- Wide variety of rotors and stators, machined by Sydex, including vacuum hardening to provide exceptional service life.
- Reinforced bearings configuration for big sizes pumps.



● *Close-coupled BK version (stainless steel)*

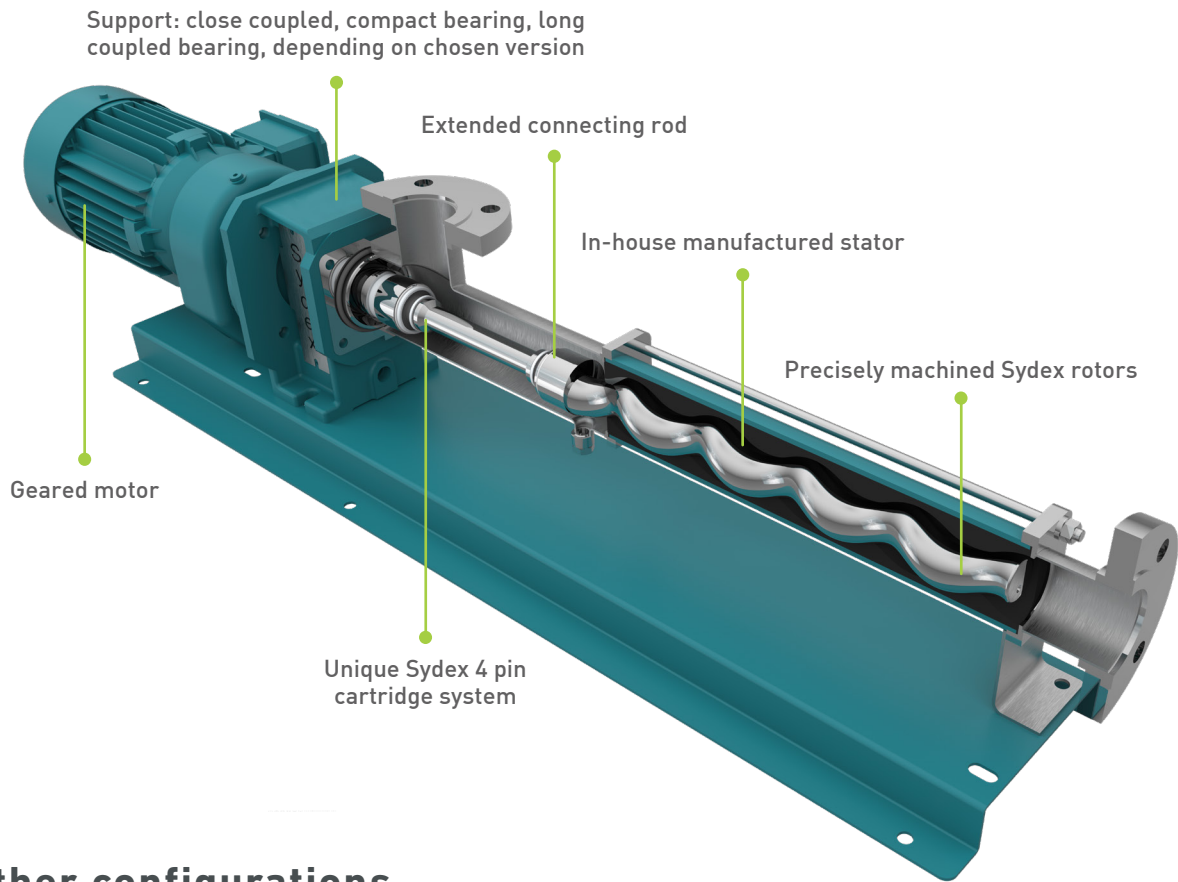

Other configurations

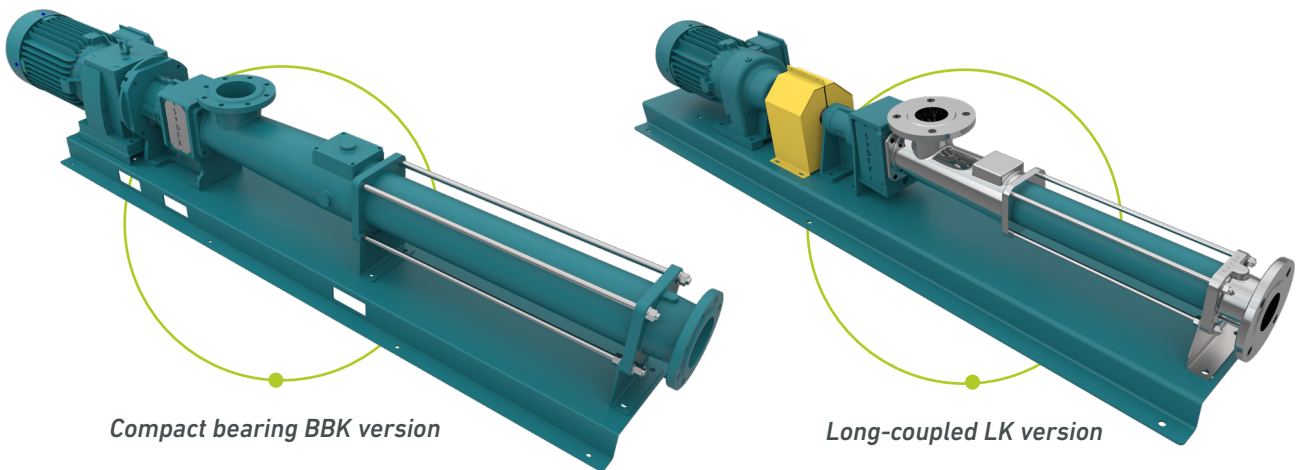

Application fields

- Industrial applications in environmental technology.
- Industrial applications in the food industry.
- Industrial applications in the oil & gas industry.
- Industrial applications in the chemical industry.
- Industrial applications for a wide range of fluids with different viscosities.

M Range

Metering Progressing Cavity Pumps

The M range metering progressing cavity pump series is designed specifically for dosing any kind of liquid.

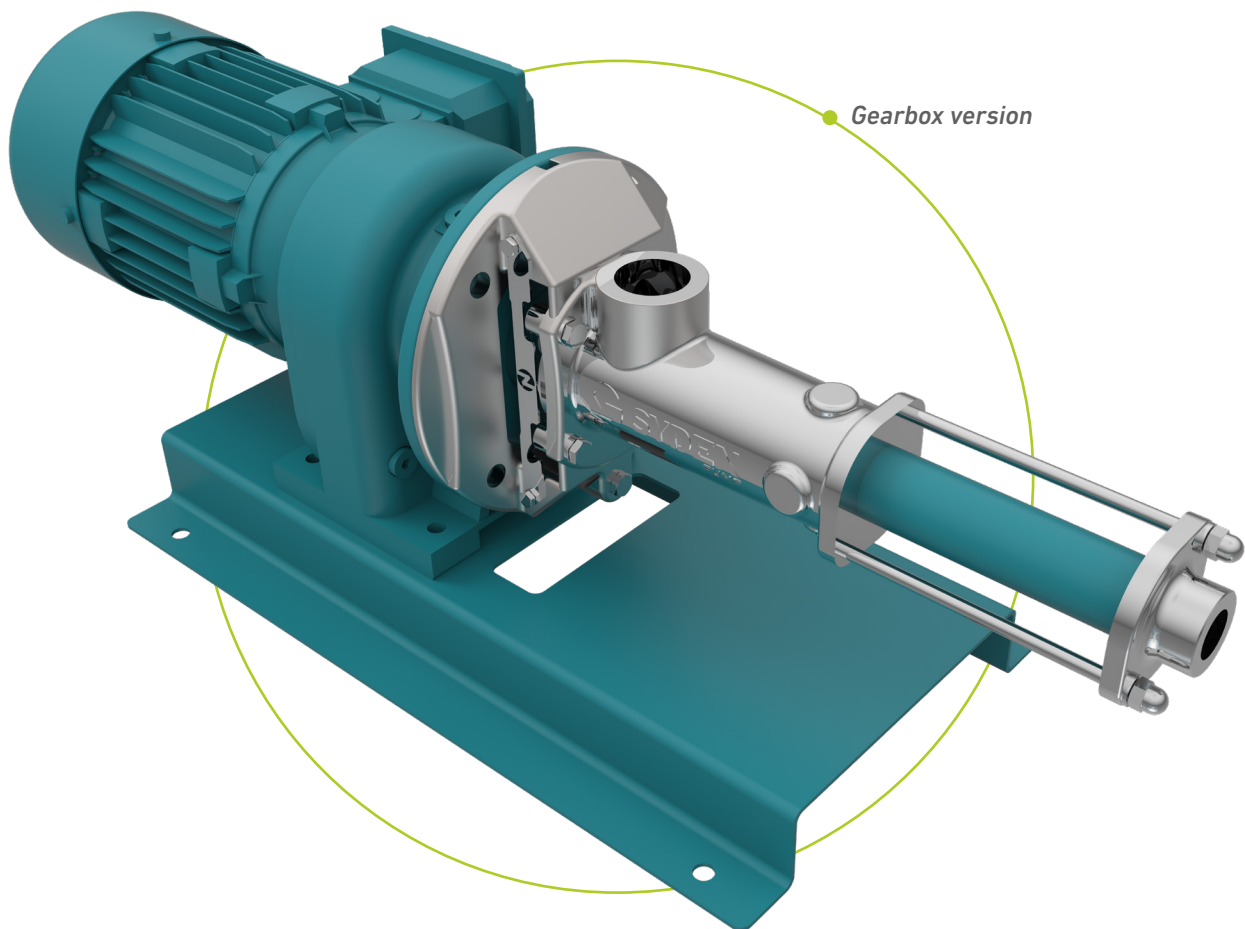

Advantages

- Robust design, clearest delivery time and best value for money in the market.
- Wide pumps range.
- Extremely high accuracy with the maximum variation of $\pm 1\%$.
- Easy and reliable control of dosing capacity.
- Different rotor and stator sizes and different dosing capacities within one modular design envelope.
- Quick assembling and disassembling system.

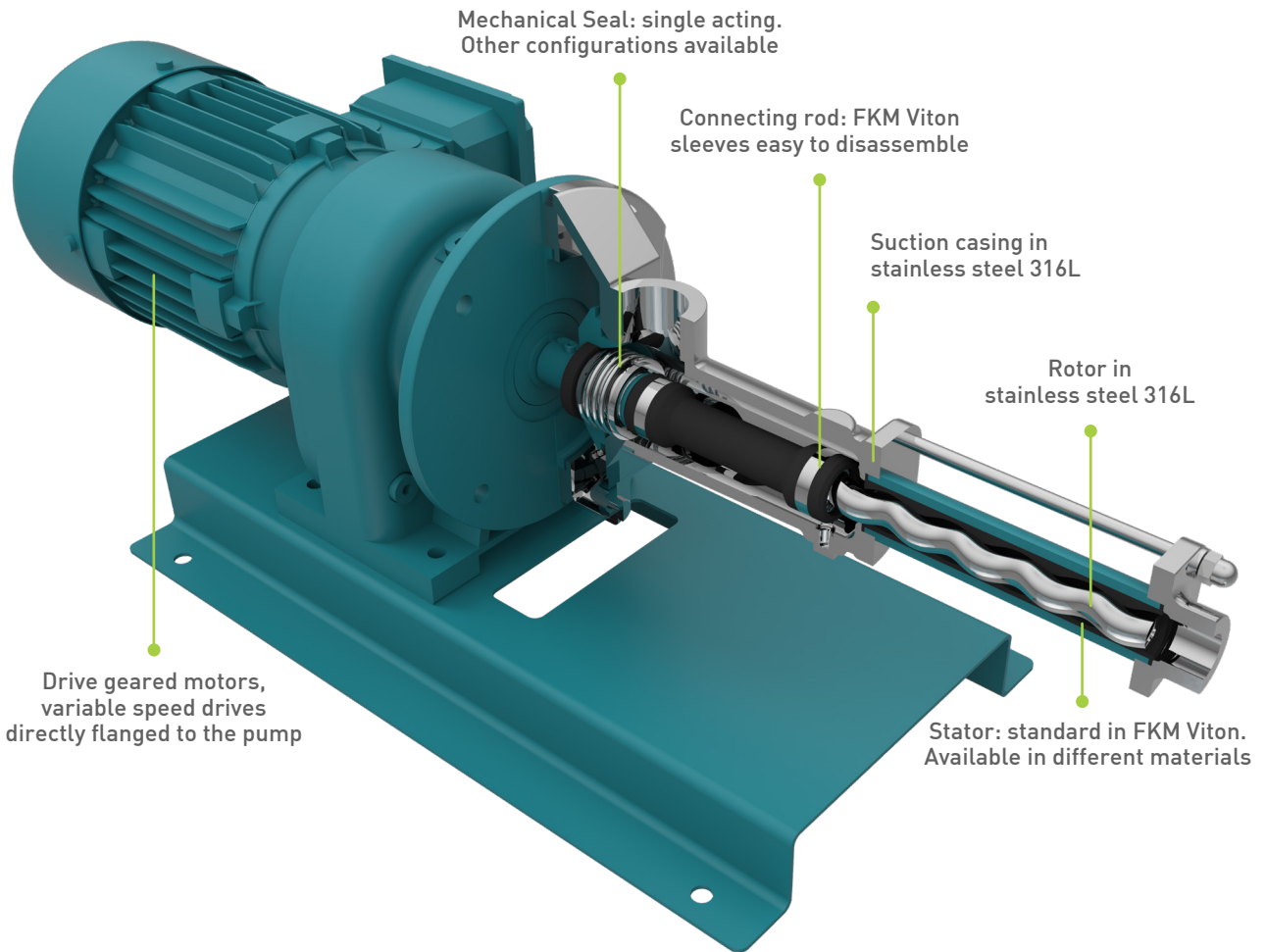

Other configurations

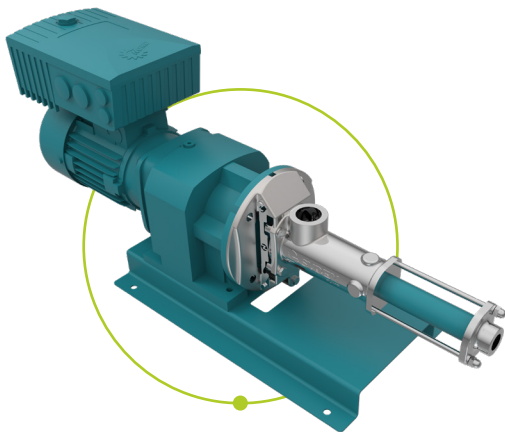

Gearmotor with VFD version

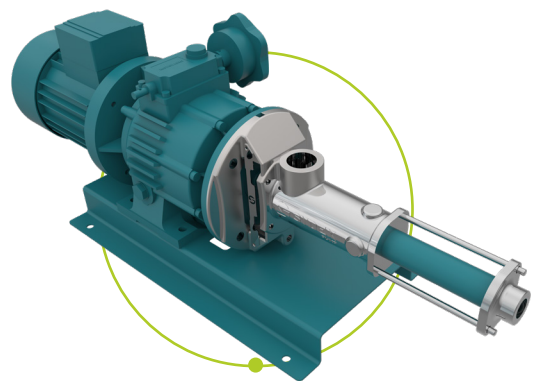

Motovariator version

Application fields

- Industrial applications in environmental technology.
- Industrial applications in the oil & gas industry.
- Industrial applications in the chemical industry.
- Industrial metering applications.

H Range

Hygienic Progressing Cavity Pumps

Designed to meet the strictest food requirements, the hygienic progressing cavity pump is ideal for fragile food products handling.



The Sydex Hygienic Progressing Cavity Pumps comply with CE 1935/2004 (EU) requirements which guarantee the materials compatibility with food products and equipment traceability.

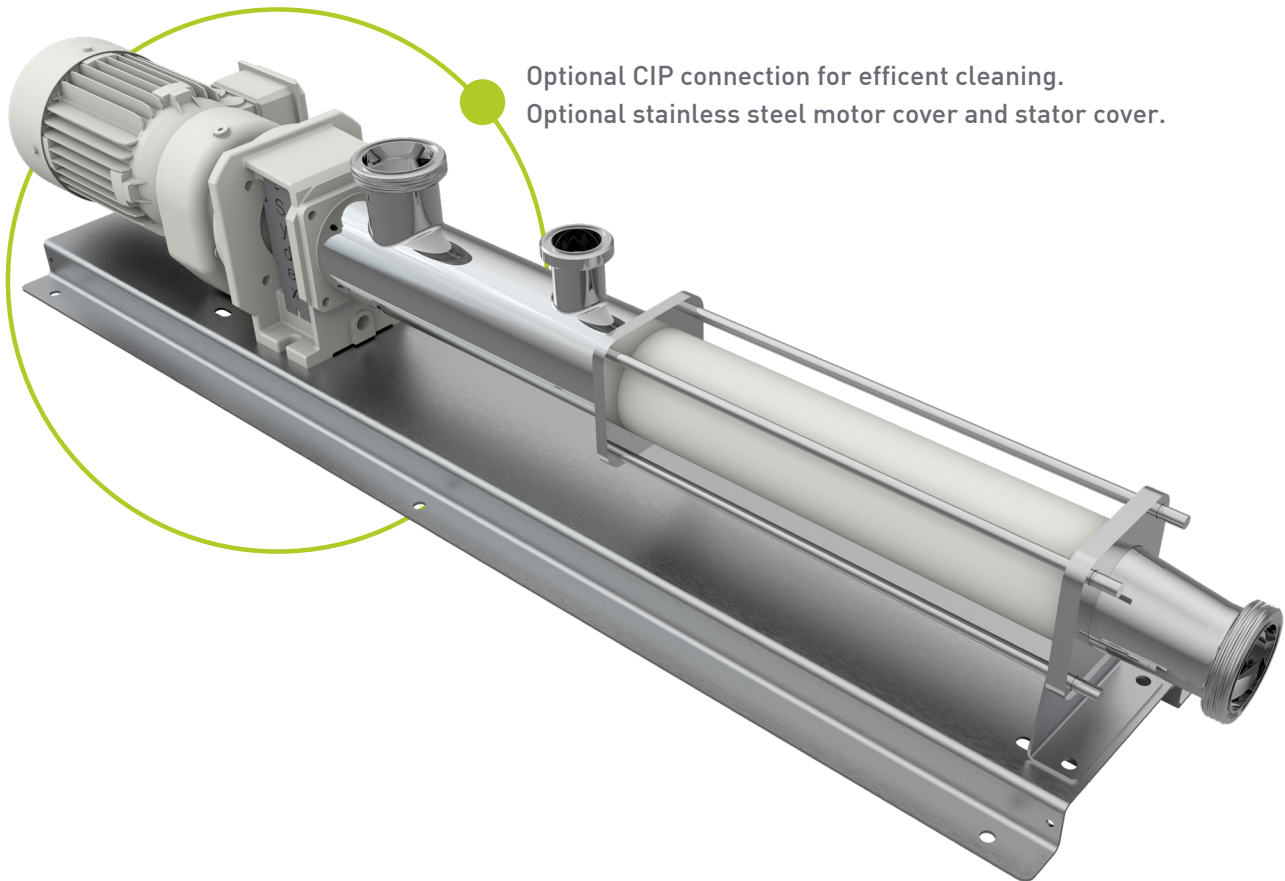

Advantages

- Robust design, clearest delivery time and best value for money in the market.
- Wide pumps models.
- Agility and flexibility in production.
- Hygienic open pin joint system ensuring no contamination of pumped product.
- Seal housing specially designed to remove “dead areas”.
- FDA certified elastomers stators (stainless steel covers fitted as an option).
- Easy cleaning of the process line thanks to the stainless steel baseplate with support feet.



HF

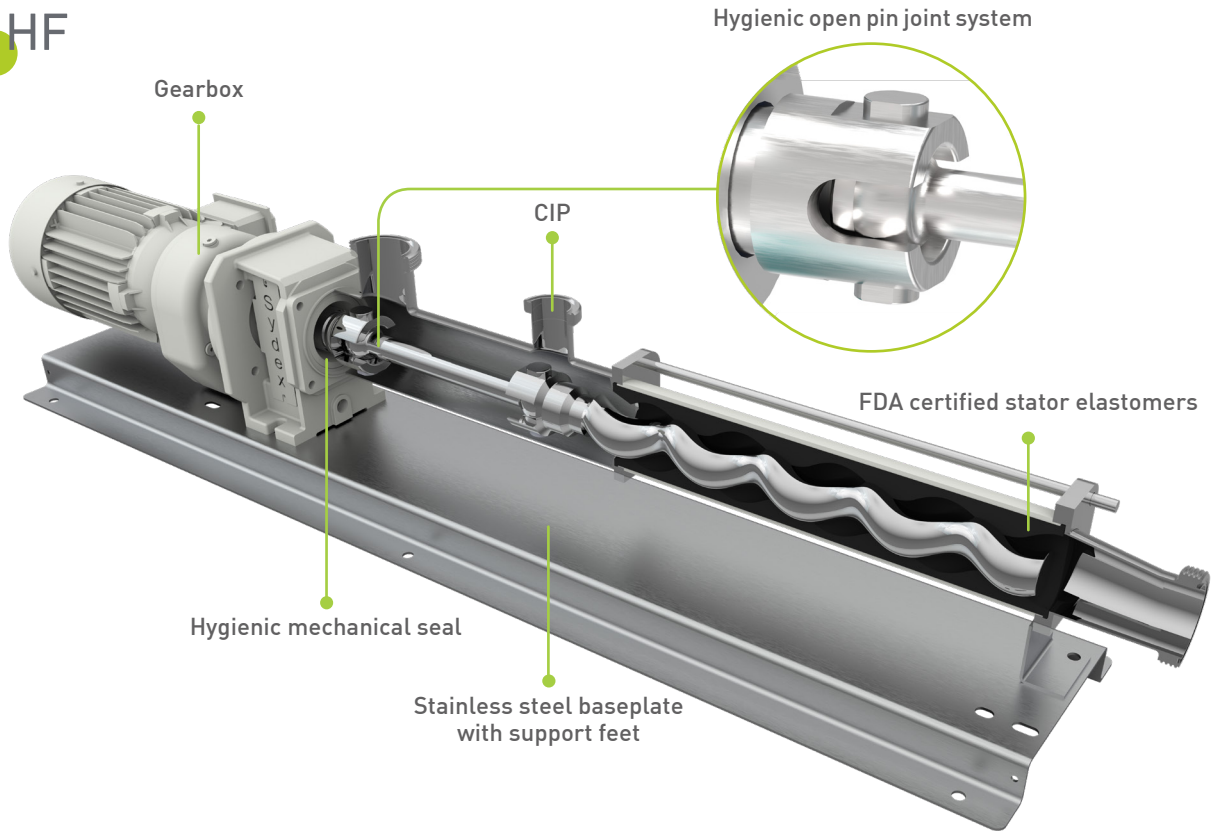

HL

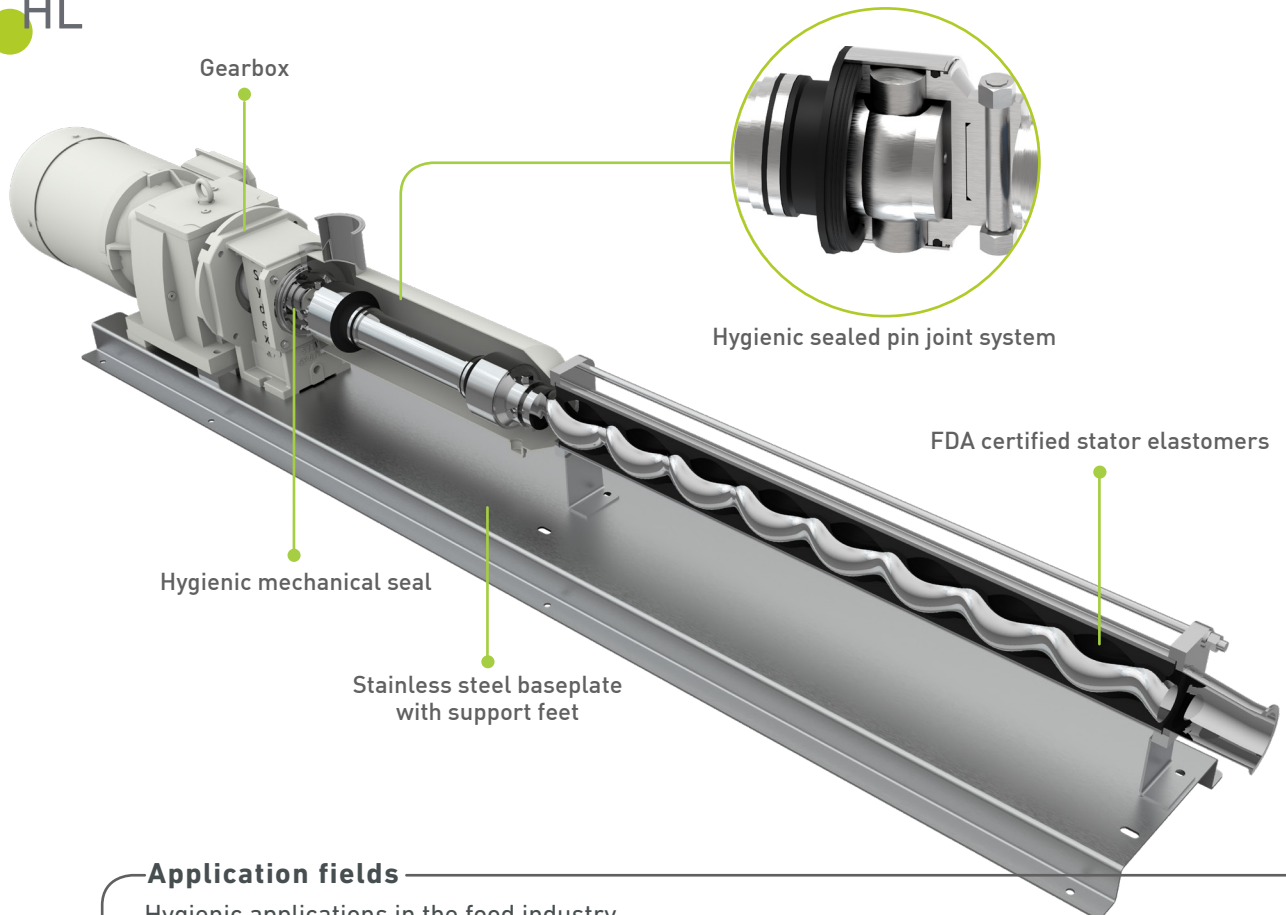

Application fields

- Hygienic applications in the food industry.
- Hygienic applications in the chemical industry.
- Hygienic applications for fluid and viscous media with and without solids.

WH Configuration

Hopper Progressing Cavity Pumps. *For viscous and non-homogeneous products*

WH Pumps are the ideal solution for the transfer of high-viscosity, non-homogeneous and pasty products. The pump feeding is effective thanks to the open-throat design of the hopper and to the conveyor screw, which ensure the transfer of the product without any restriction.

This is a compact solution for a simplified integration, a small investment and a low power consumption.

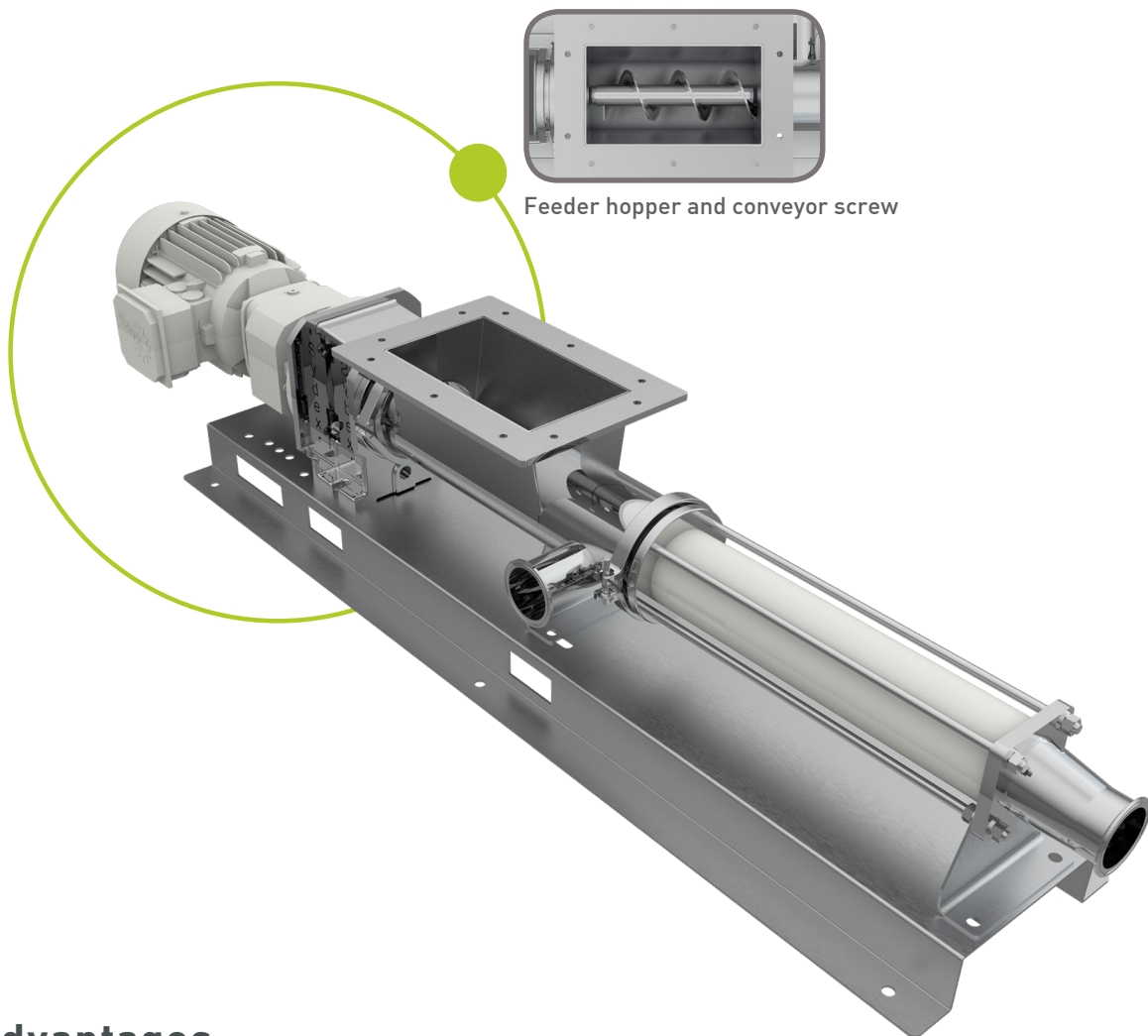

Feeder hopper and conveyor screw

Advantages

- Robust design, clearest delivery time and best value for money in the market.
- Wide pump models.
- Agility and flexibility in production.
- Hygienic open pin joint system ensuring no contamination of pumped product.
- Seal housing specially designed to remove “dead areas”.
- FDA certified elastomers stators including white nitrile (stainless steel covers fitted as an option).
- Easy cleaning of the process line thanks to the stainless steel baseplate with support feet.

WHF

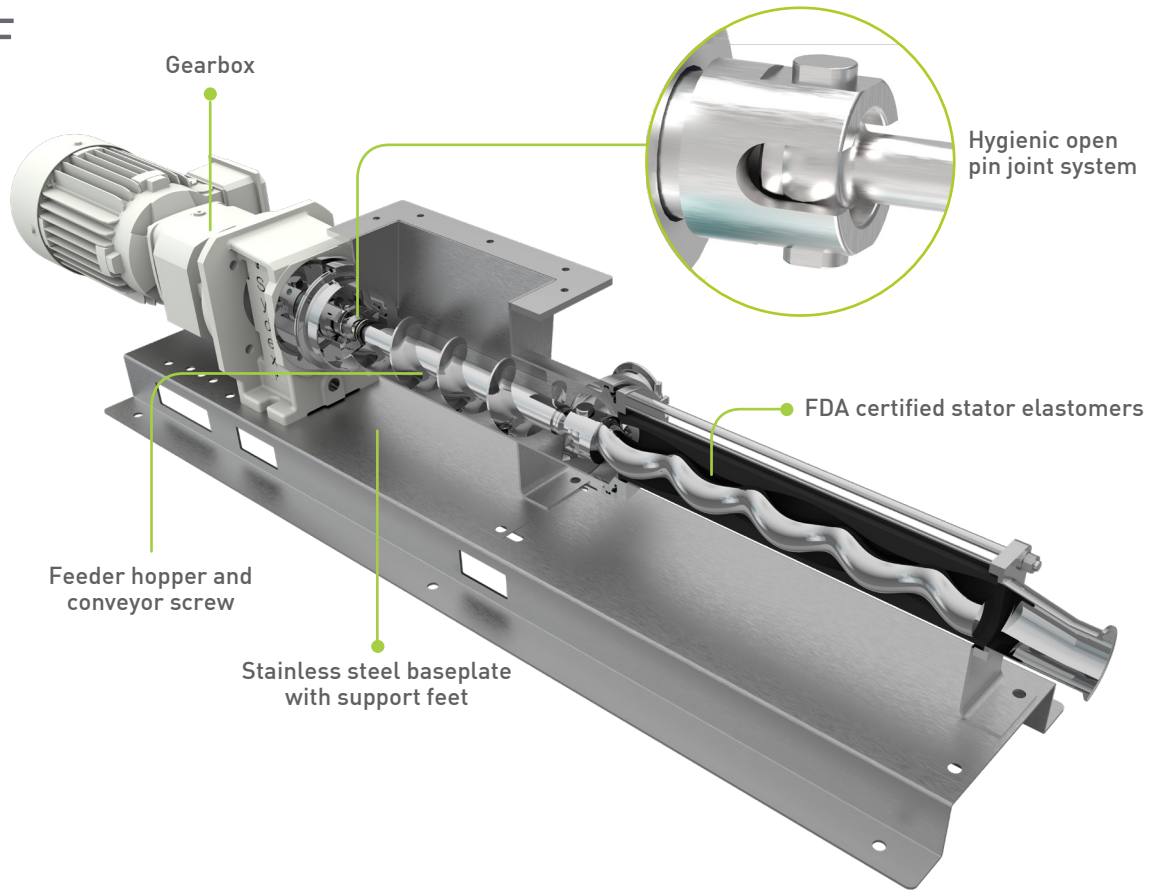

WHL

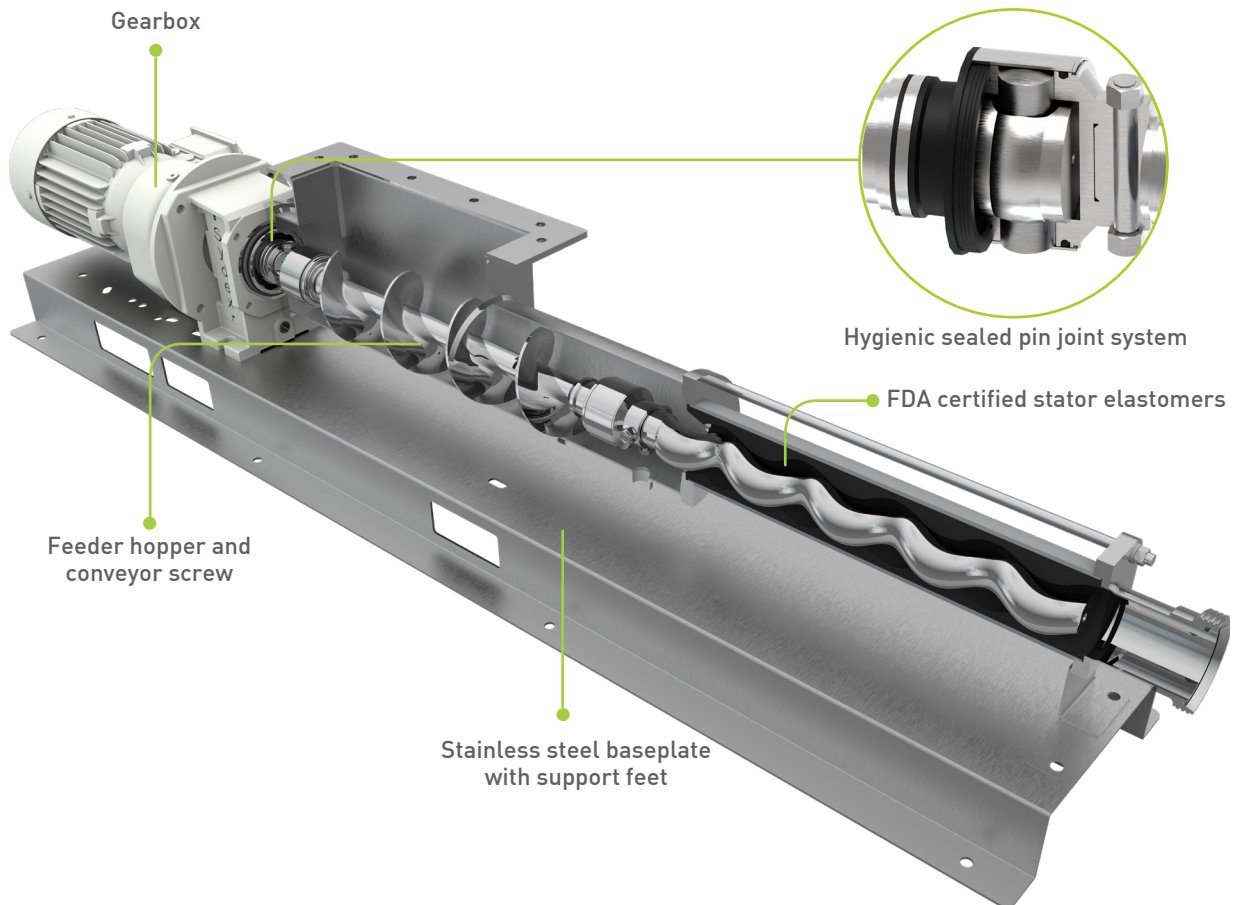

W range

Hopper Progressing Cavity Pumps

This pump is ideal for industrial applications in environmental technology, as well as in food industry and chemical industry, for transferring viscous and non-free flowing media, both with or without solid particles.

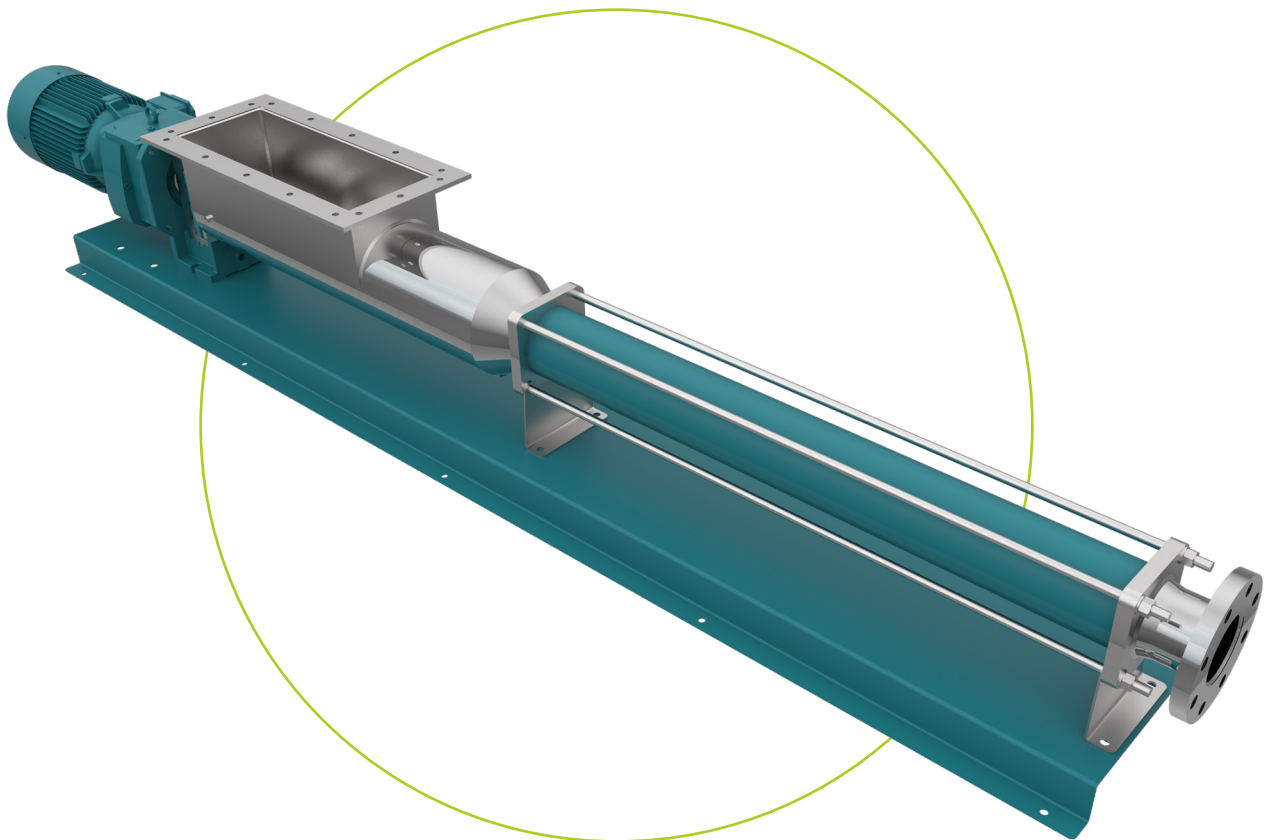

Advantages

- Robust design, clearest delivery time and best value for money in the market.
- Wide pumps models.
- Large variety of construction materials.
- Efficient conveyance into the pumping chamber through the angular sided hopper, which is designed to guide high viscosity or non-free flowing liquids to auger.
- Maximum conveying efficiency with the auger design.
- In-house stator manufacturing ensuring optimized geometry, performance and reliability.
- In-house machined rotor available in different materials.

The W range has been specifically developed to handle difficult to pump, non-Newtonian liquids and products with viscosities greater than 10,000 Cps. It is provided with a feed screw, mounted inside the hopper to convey the liquid into the pumping element (stator and rotor) enabling a trouble-free efficient pumping solution that few other pumps can provide.

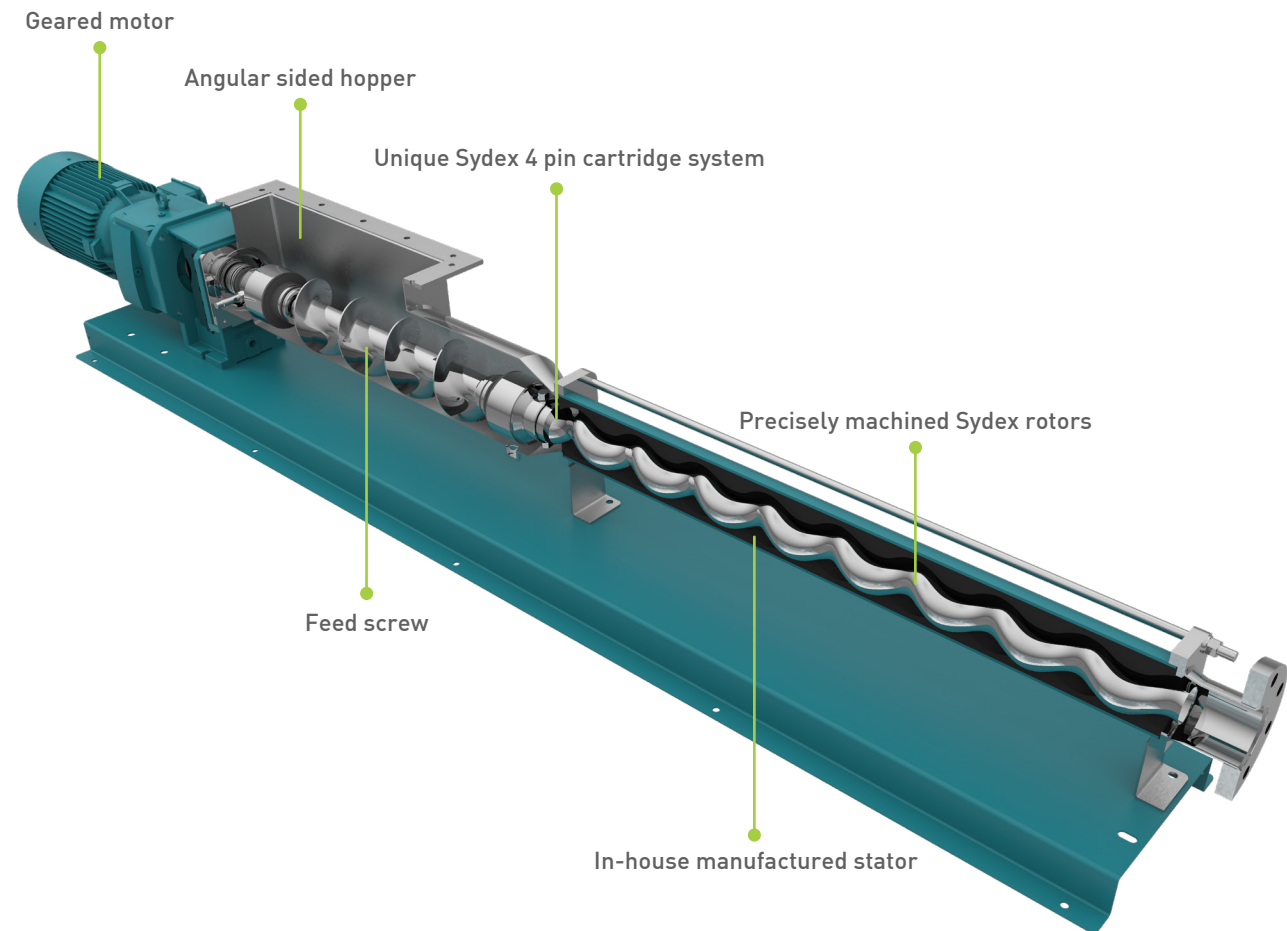

Application fields

- Industrial applications in environmental technology.
- Industrial applications in the food industry.
- Industrial applications in the oil & gas industry.
- Industrial applications in the chemical industry.
- Industrial applications for fluid and viscous media with and without solids.

WL range

Mobile Hopper Progressing Cavity Pumps

Specially designed for the wine production, the WL range is provided with trolley and control panel.

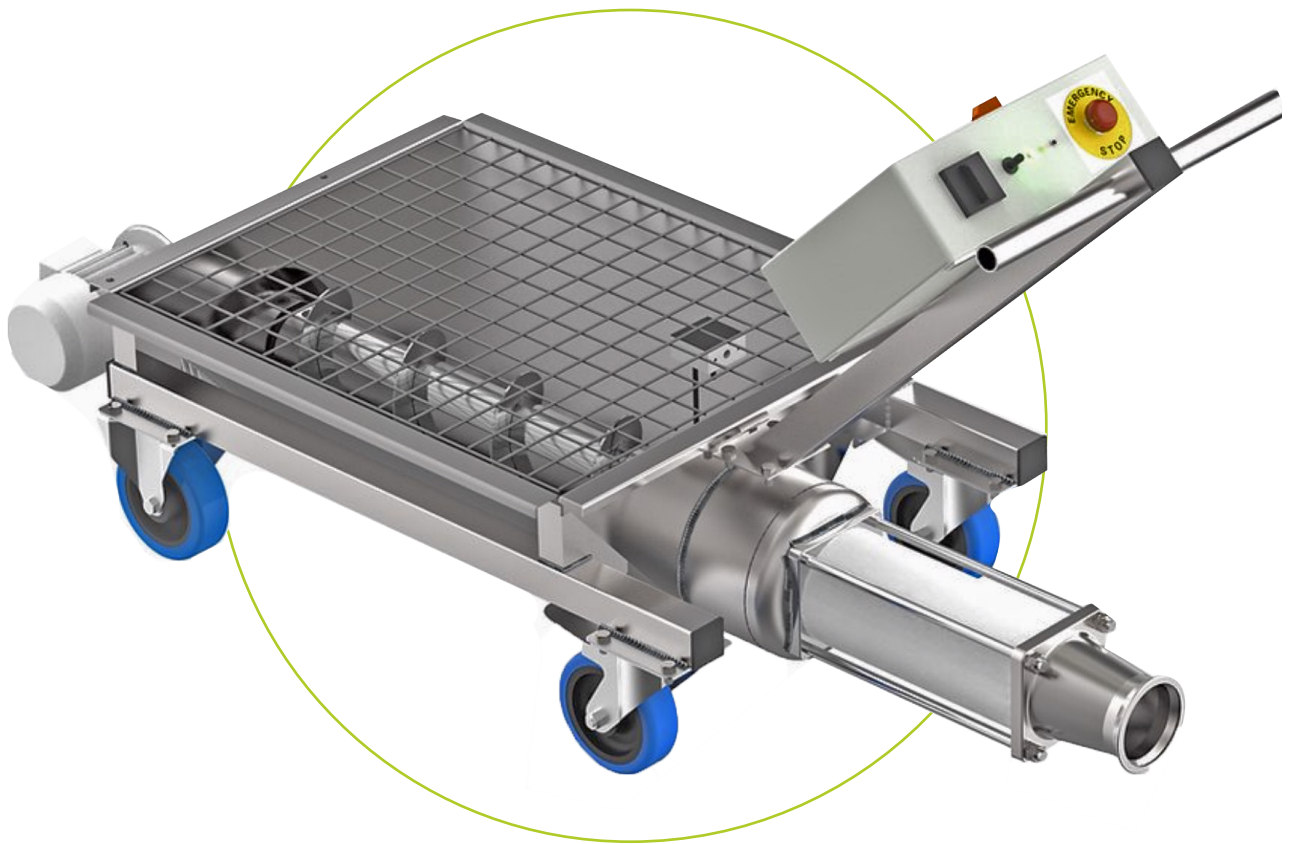

Advantages

- Robust design, clearest delivery time and best value for money in the market.
- Wide pumps range.
- Open joint to allow easy cleaning.
- CE electrical control panel with sophisticated options to provide start-stop and pump protection.
- Stainless steel auger, pitched matched to pump speed ensuring pump charge is maintained.
- Hopper design enabling easy cleaning.



The compact and robust design of the WL mobile hopper PCP makes it ideal for transferring whole or destemmed grapes and it can be installed right under the destemmer. It can also be used during the decanting process.

This PCP model is perfectly suited for food and beverages liquids pumping such as grapes, juice, olive oil, parts of vegetables, pastes of olive or tomato, jams and preserves.

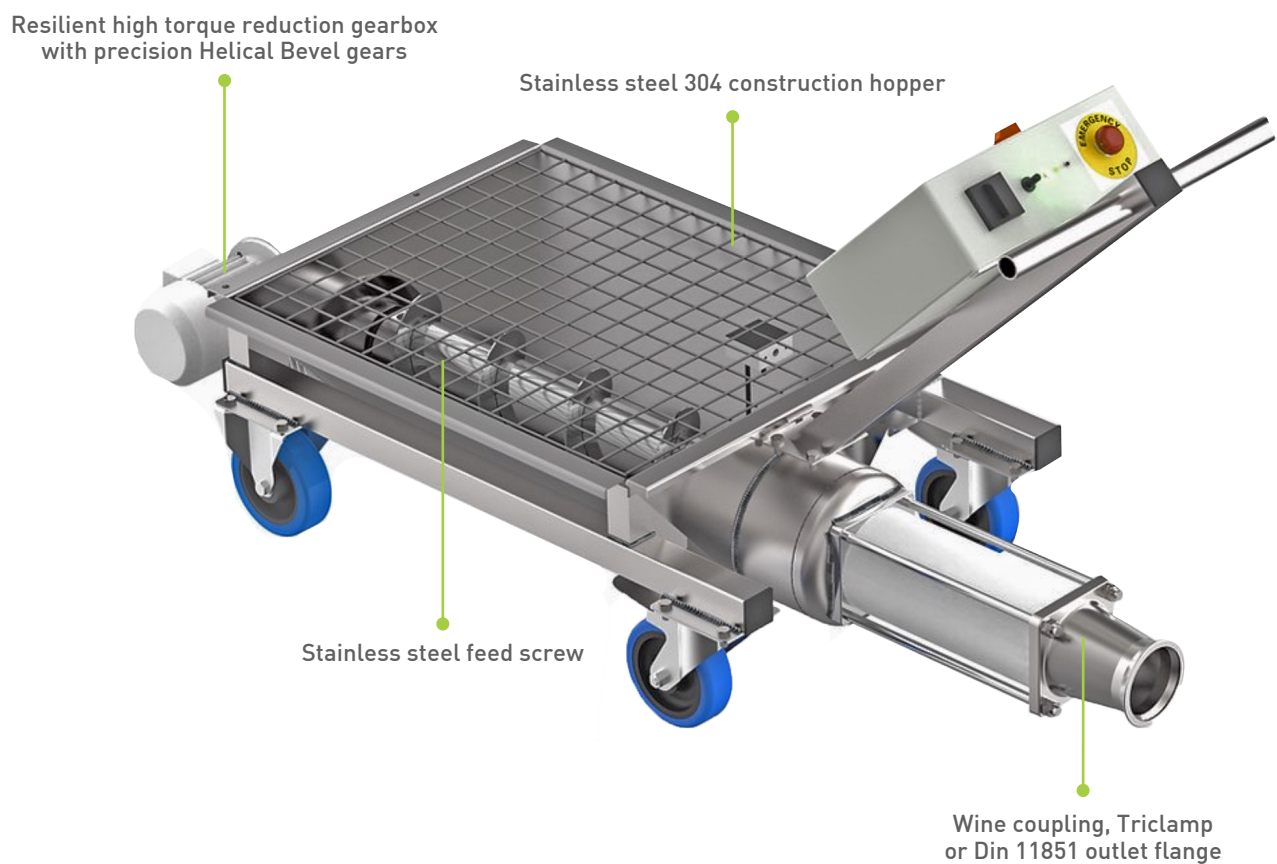

Application fields

- Industrial applications in environmental technology.
- Industrial applications in the food industry.
- Industrial applications in the oil & gas industry.
- Industrial applications the chemical industries.
- Industrial applications for fluid and viscous media with and without solids.

G range

Feeding Screw Progressing Cavity Pumps

Designed to ensure easy and efficient pumping of highly viscous, solids laden and non-Newtonian fluids.

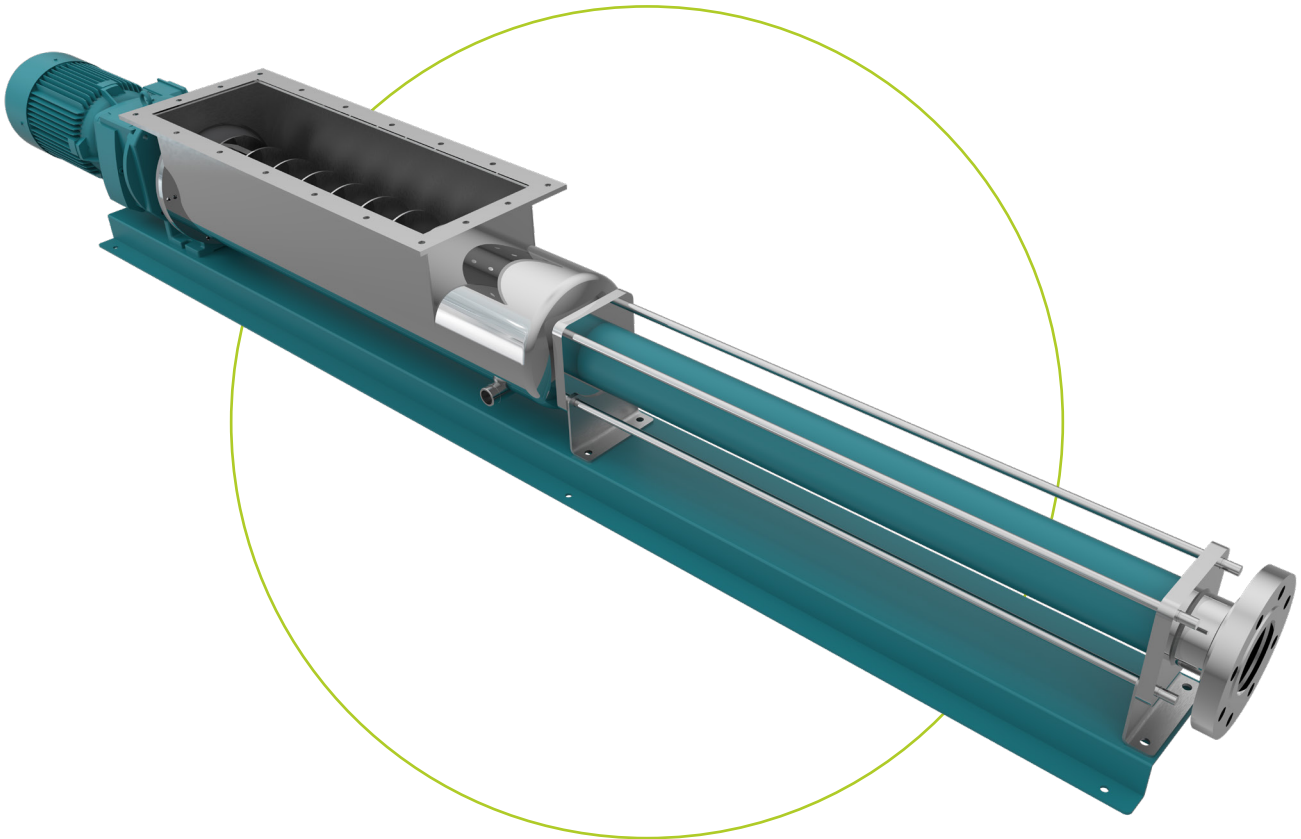

Advantages

- Robust design, clearest delivery time and best value for money in the market.
- Wide pumps range.
- Bridge breaker integrated solution to ensure optimal and constant product delivery to the pump.
- Geared motor with the most appropriated speeds according to your applications.
- Square sided hopper designed to eliminate the possible solids building up.
- Unique Sydex 4 pin cartridge system enabling higher reliability.
- Entire connecting rod and joints can be supplied as pre-assembled component making commissioning and/or replacement easier.
- Maximum conveying efficiency thanks to the auger design.

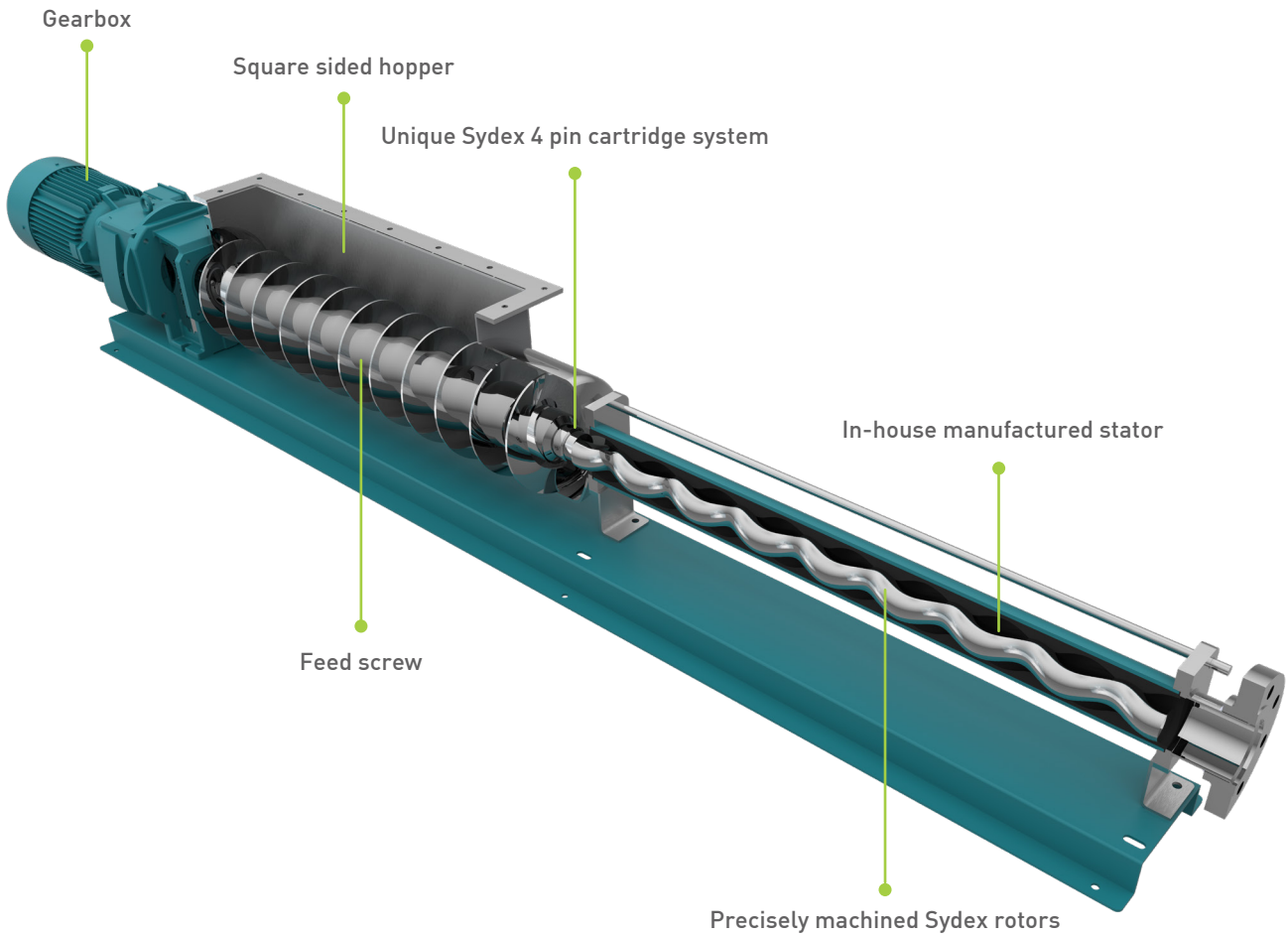

Application fields

Industrial applications in environmental technology.

Industrial applications in the food industry.

Industrial applications in the oil & gas industry.

Industrial applications for products with high viscous media with and without solids.

G-Bio

Biogas Progressing Cavity Pumps

Biogas is the combination of various gases which occur during the breakdown of organic food and waste material. The G-Bio is absolutely essential to the safe and efficient operation of today's biogas plant.

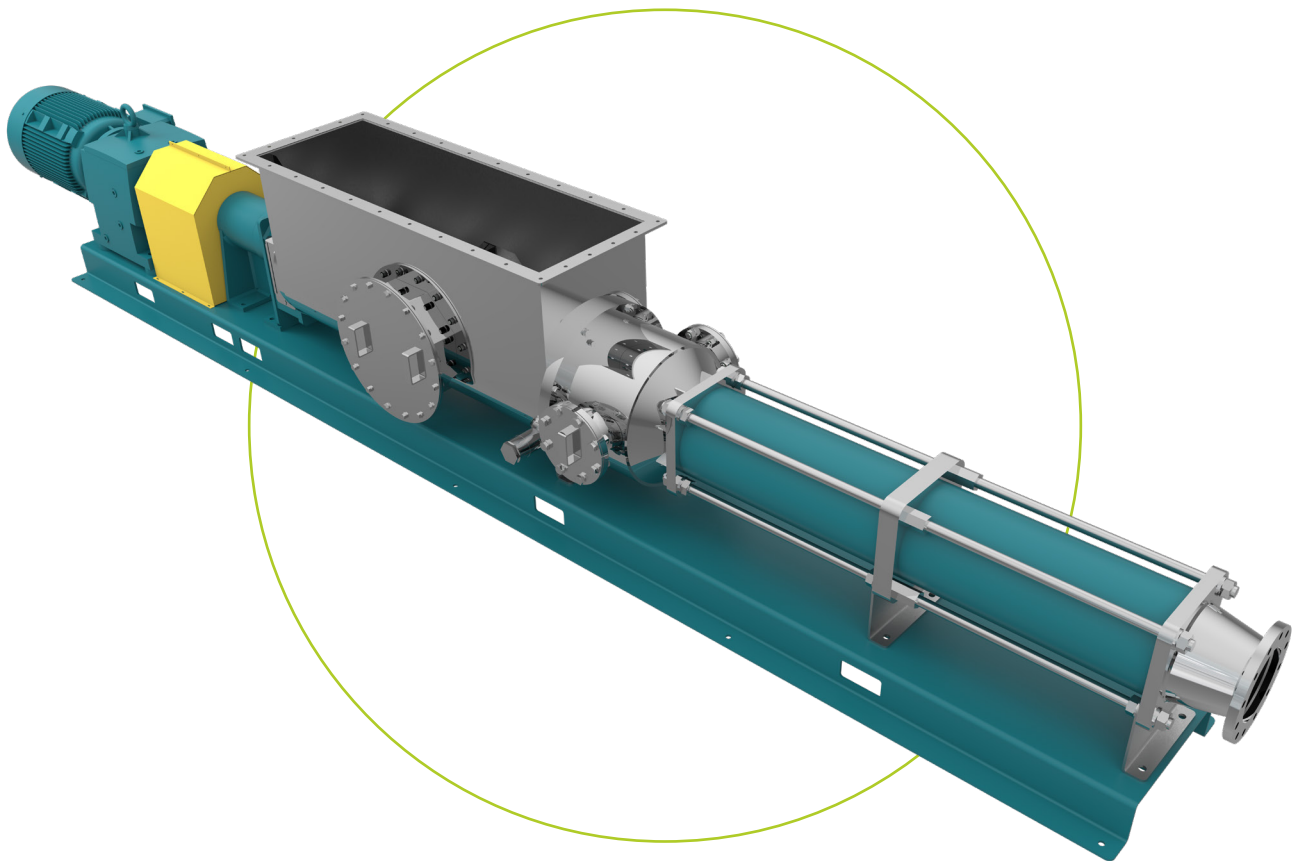

Advantages

- Robust and reliable.
- Heavy duty and high quality bearing housing ensuring long and reliable service life.
- Quick and easy maintenance operations.
- Easy access to pump chamber through a large removable cover plate.
- Ideal for biogas applications.
- No compression within the pump chamber with the hopper.
- Designed to prevent solids building up on sides.
- Efficient conveying of biogas fluids thanks to the auger design.

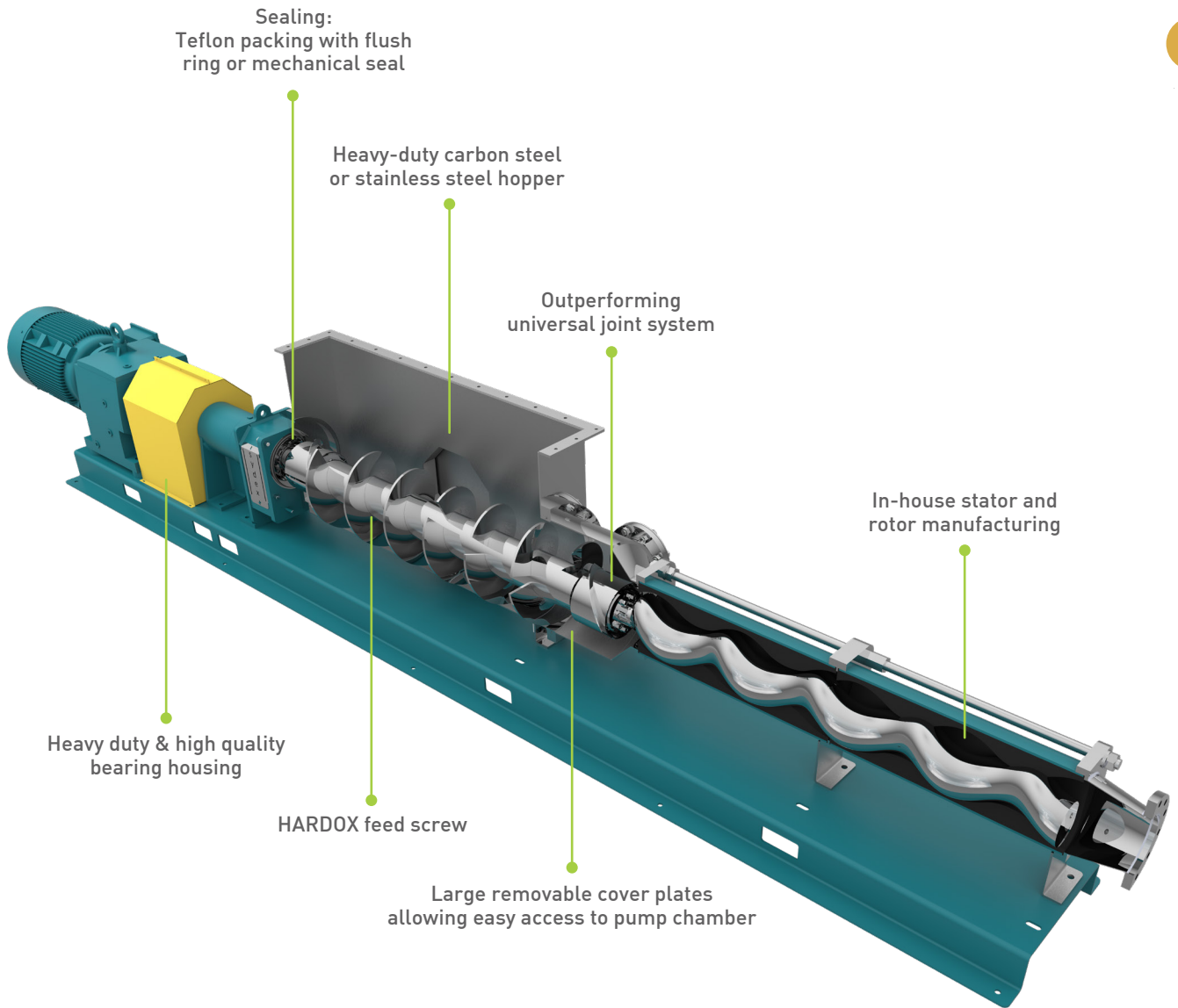

Application fields

- Industrial applications in environmental technology.
- Industrial applications in the food industry.
- Industrial applications in the oil & gas industry.
- Industrial applications for fluids with high viscous media with and without solids.

E Range

Vertical Progressing Cavity Pumps

Through its vertical configuration, it can be used as barrel and drum emptying pump.

It is also ideal for high viscosity and shear sensitive fluids.

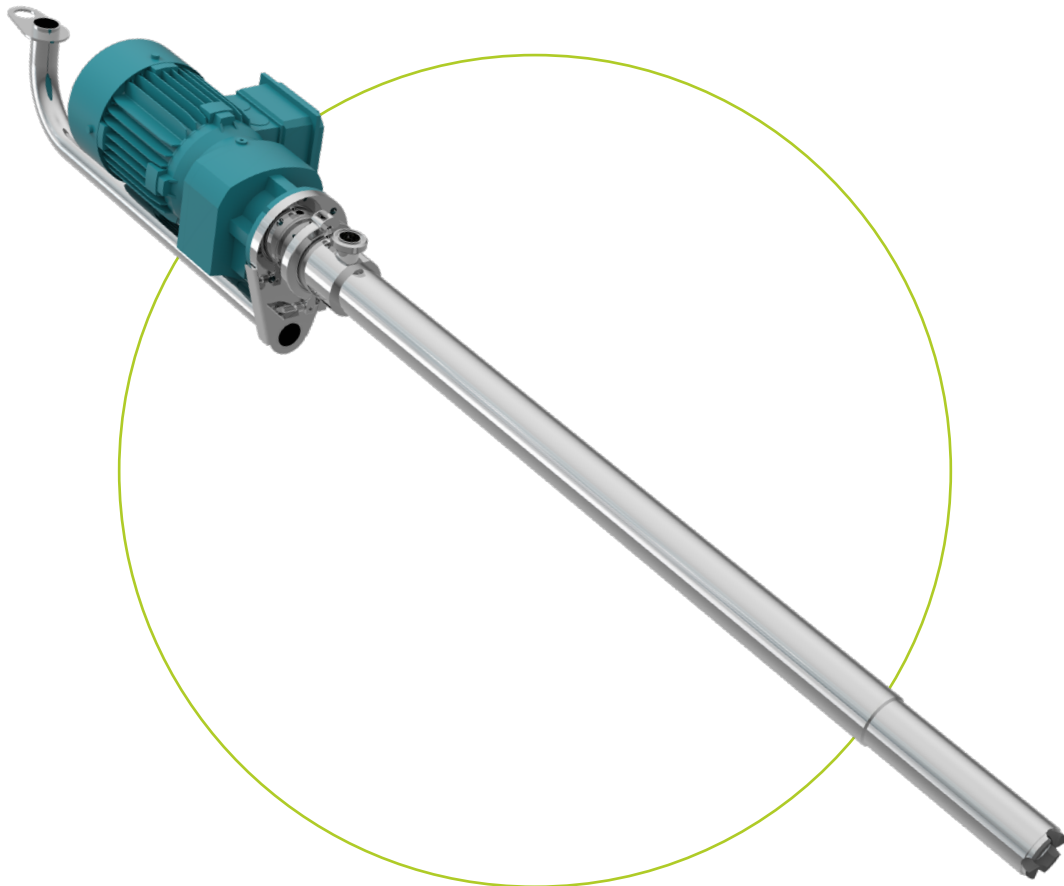

Advantages

- Robust design, clearest delivery time and best value for money in the market.
- Wide pumps range.
- Stable pump with low pulsation.
- High self-priming rate.
- Large choice of construction materials (Cast iron body, SS304, SS316, Duplex, Super Duplex).
- Self-supporting pump.
- Low level multi point entry port for efficient emptying with little wastage.
- Various outlet port options including quick release & Hygienic couplings, BSP, Din and ANSI flanges.
- Single mechanical seal as standard - other sealing options available.
- Flexible high torque drive shaft.
- Maximum pump utilisation and reduced drum cleaning effort.
- Completely dismantable and cleanable.
- No leakage when the pump is turned over or at an inclined position.

Ideal for drain full containers, basins and barrels. These pumps convey abrasive or corrosive conveying products with low to high viscosity. Individually sized and designed for the application, they are easy to maintain and have low operating costs.

Vertical progressing cavity pumps are a cost-effective alternative to other pump systems.

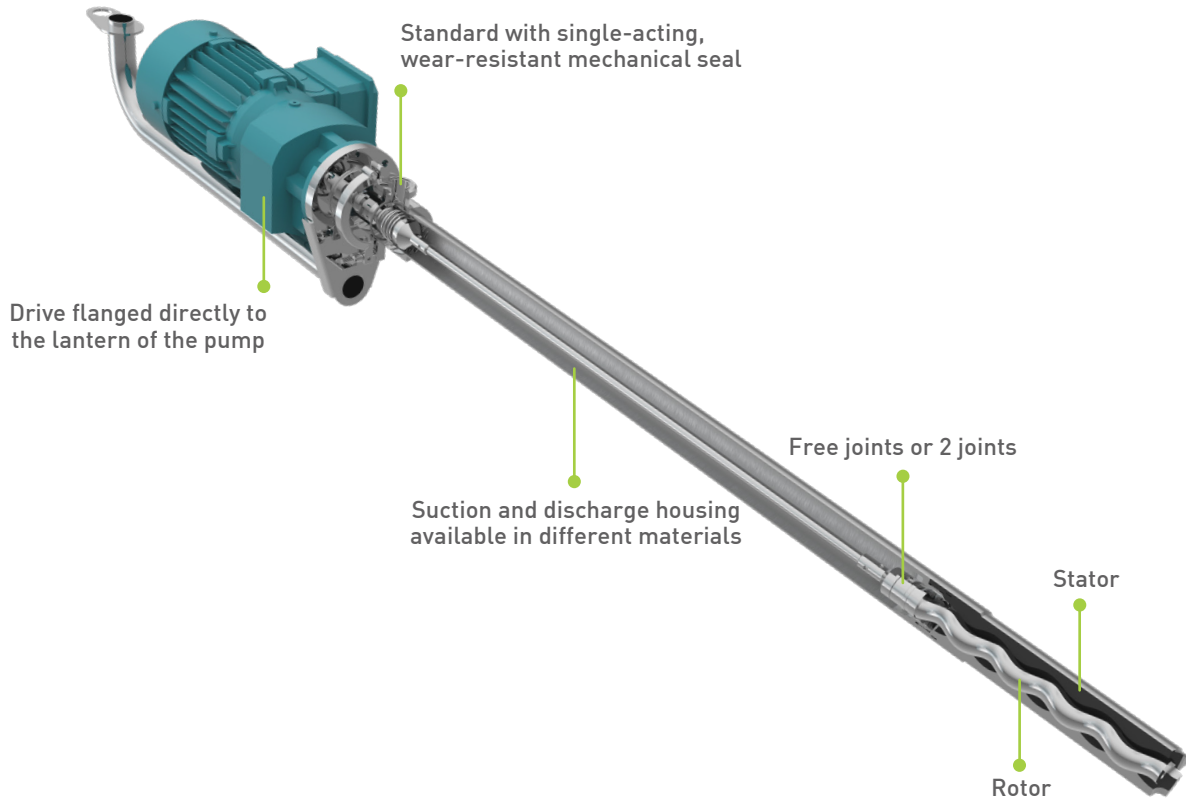

BE *Vertical barrel and drum progressing cavity pumps*

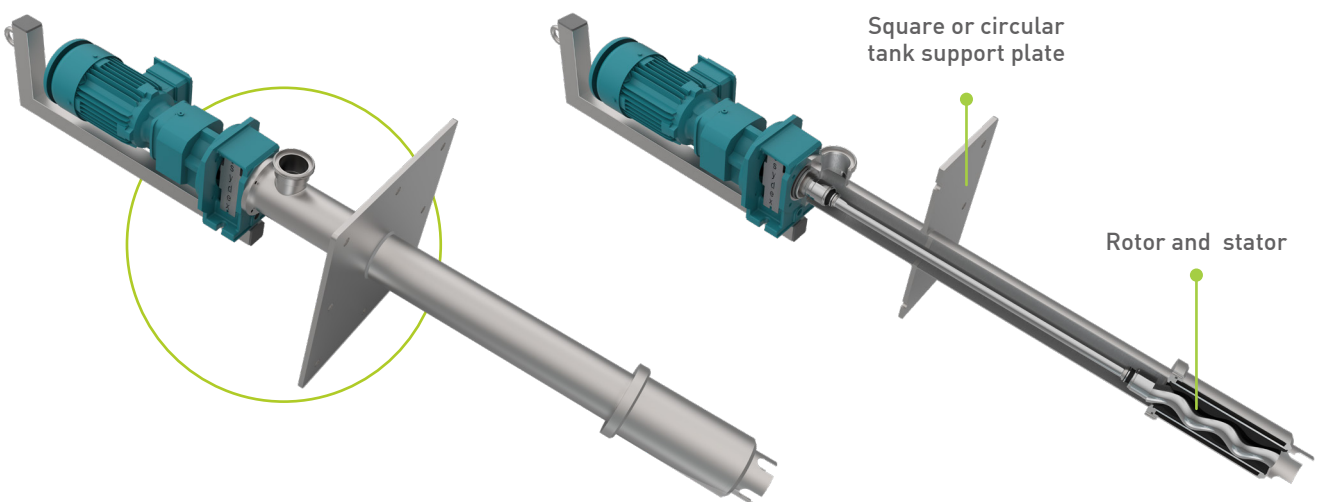

Application fields

Ideal for corrosive and neutral, aqueous to slightly viscous fluids.

For draining basins, swamps, tanks, pits and containers of every kind.



FM Range

Compact Progressing Cavity Pumps

Compact and versatile, the FM Range brings you all the advantages of progressing cavity pumps, in a small, compact and economical design.

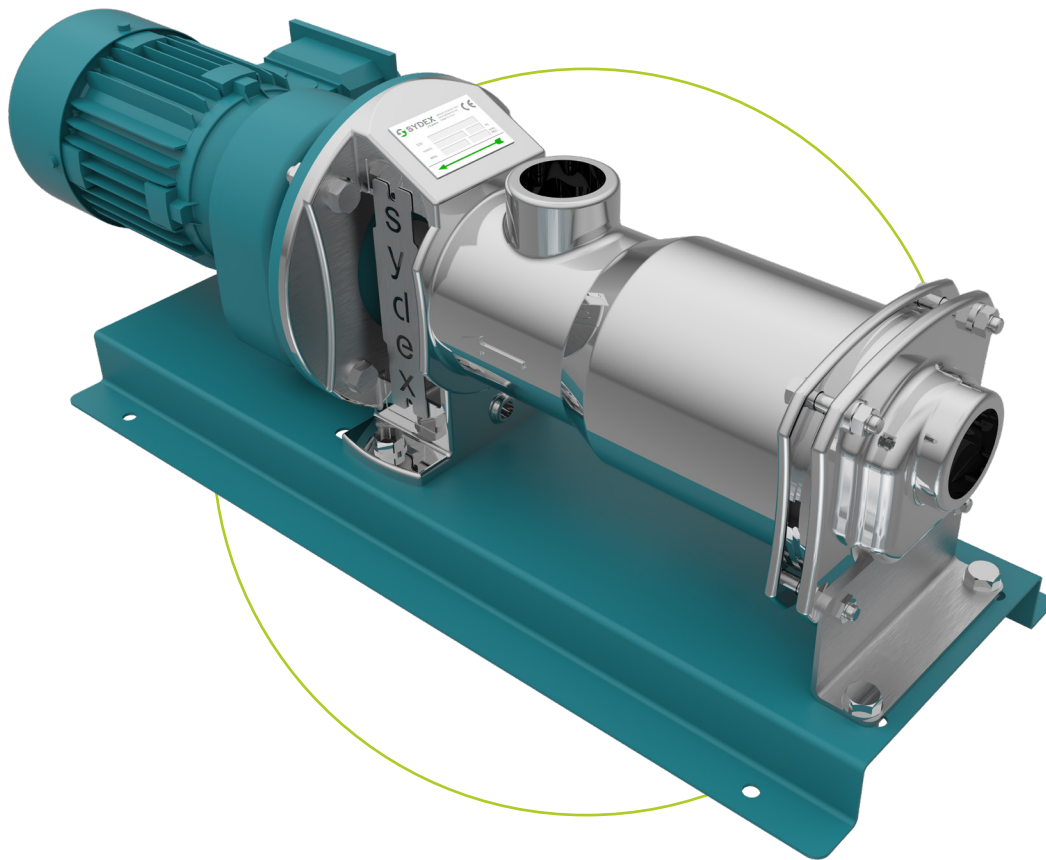

Advantages

- Low noise emissions.
- Low cost of ownership.
- Non-pulsating reliable flow.
- High performance combined with efficient design.
- Different material combinations available to suit applications.
- Extremely simple maintenance.
- Self priming, ideal for suction lifts.
- Wide range of flows 20 up to 10.000 l/h.

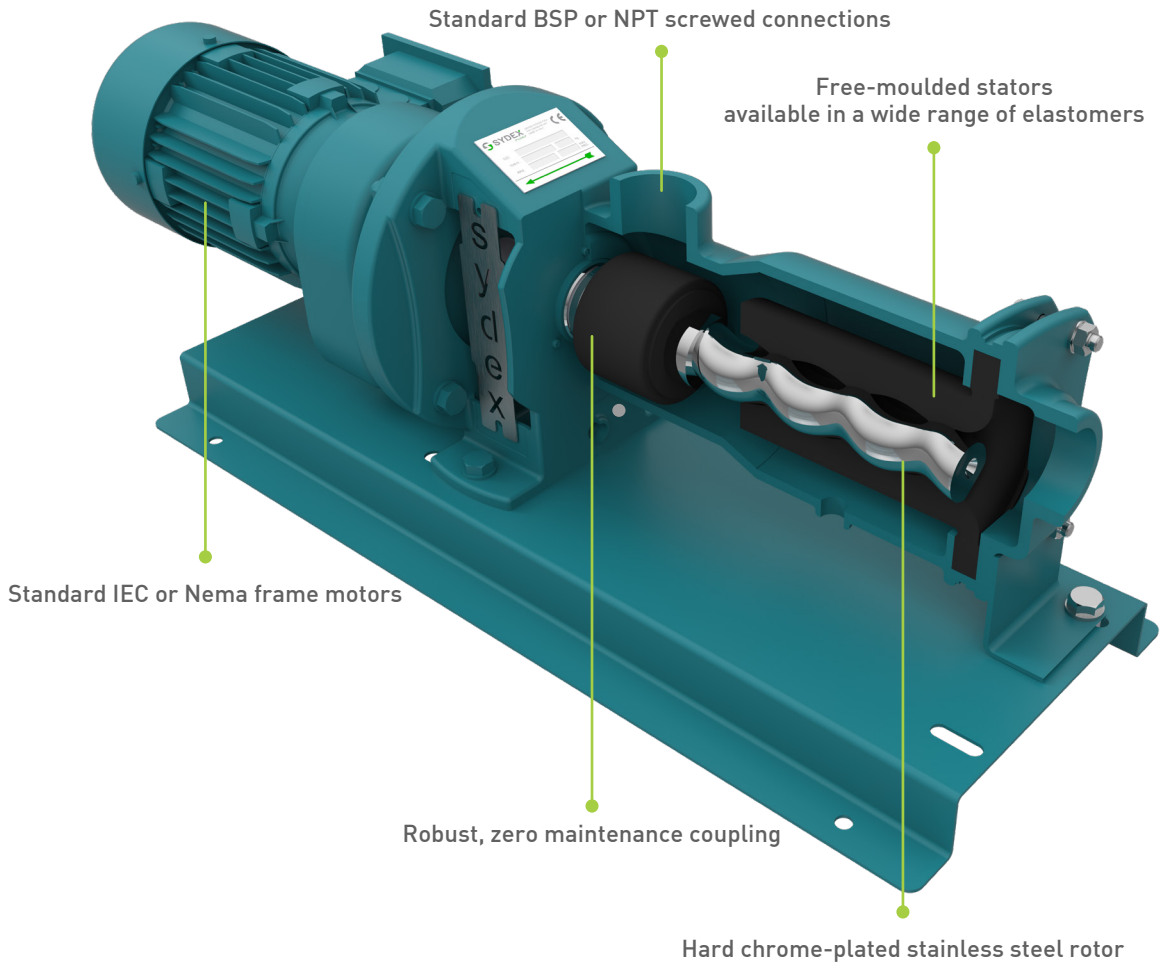

Configurations

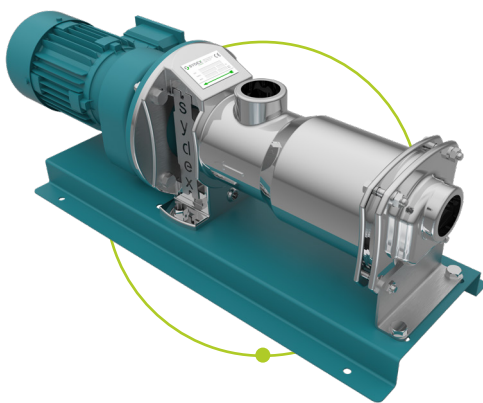

Stainless steel

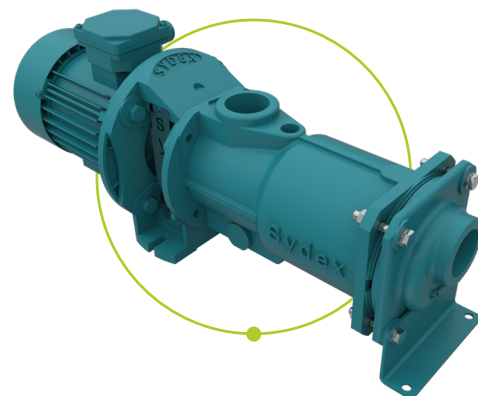

Cast-iron

Application fields

Drainage applications, sampling duties and solids handling.
 Dosing Polymer, bilge pump on board.
 Ideal for OEM pump applications.

API 676

The American Petroleum Institute (API) sets standards for equipment, materials of construction, operating procedures and safe practice in the Oil and Gas industry.

Our pumps for Oil and Gas applications are designed to comply with API 676 requirements.

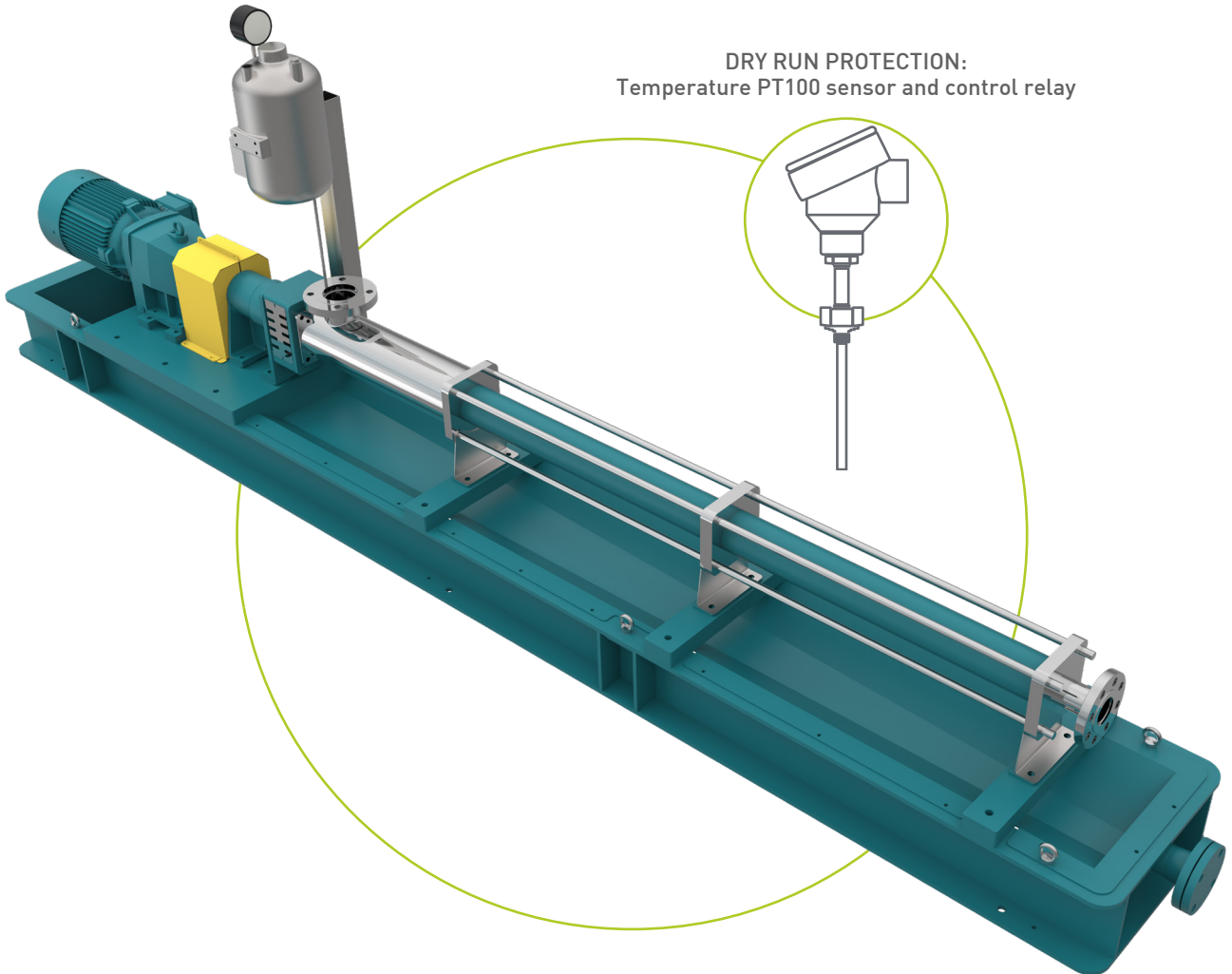

Advantages

- Gentle transfer of fluids with low shearing effect.
- Lowest NPSH.
- Effective handling of a large range of viscosities.
- Effective handling of fluids with suspended solids such and free gas.
- Easy maintenance.
- Reversible flow on request.
- Flow rate proportional to running speed.
- Super duplex stainless steel wetted parts.

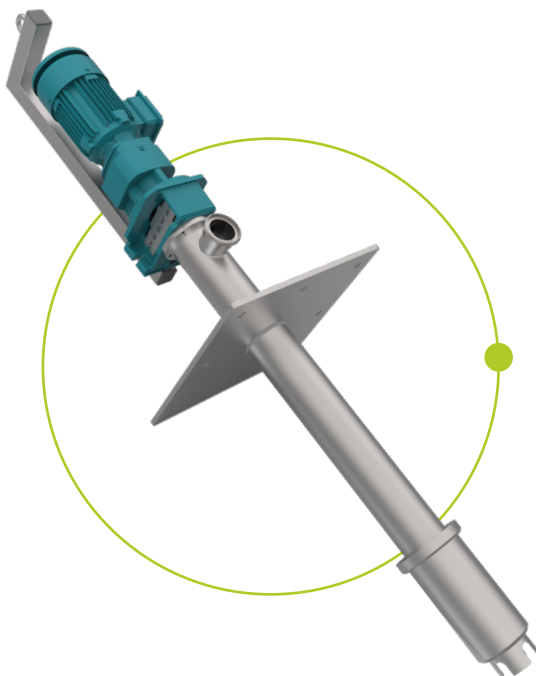
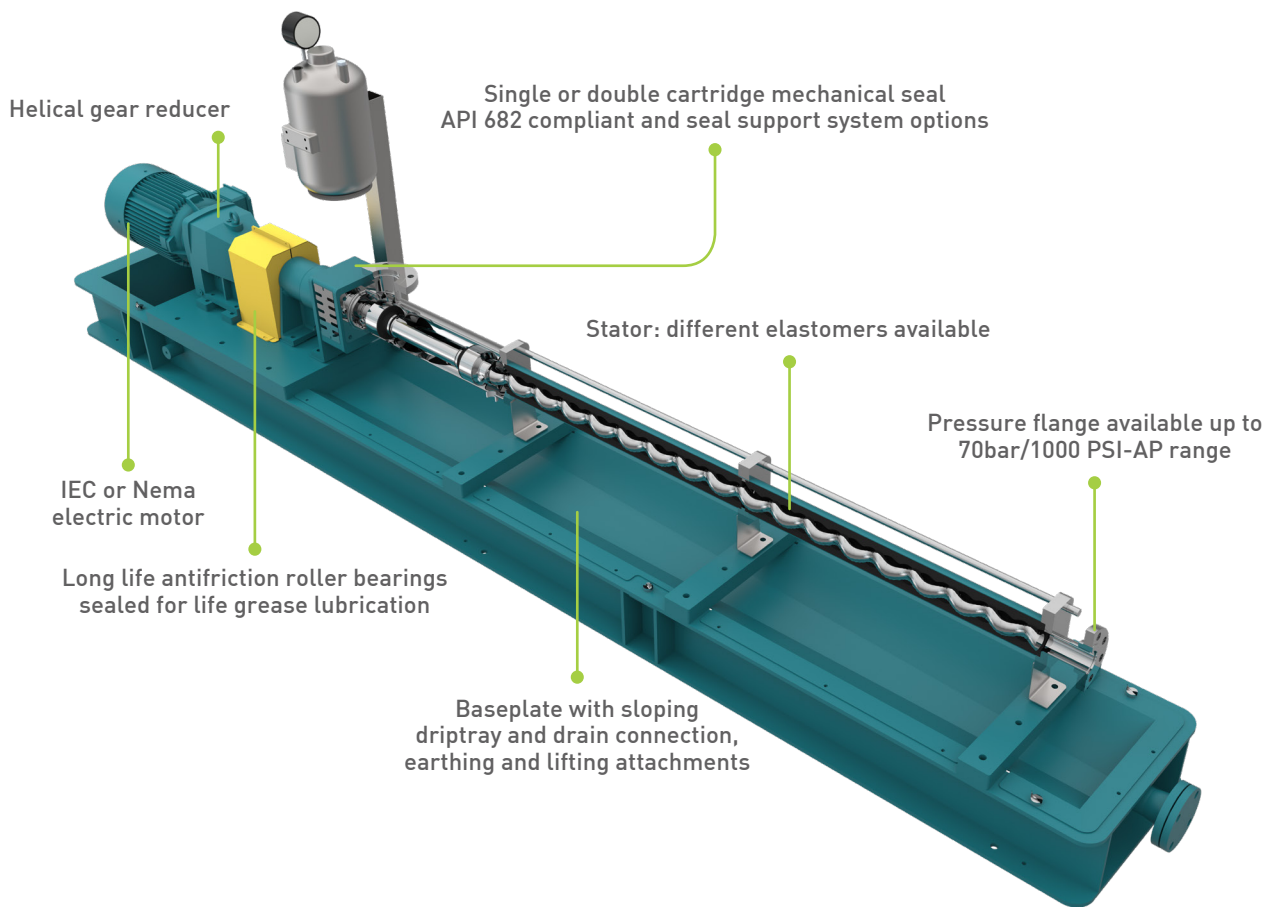

The **vertical configuration** is ideal to suit the constraints of confined spaces, reducing the equipment footprint. They can be mounted on a drum, caisson or inside a tank, keeping the motor safe from any potential hazardous and/or corrosive environment. Our API 676 pumps are manufactured and tested to very high specifications.

Application fields

- Flare knock-out drum pumps. Produced water pumps.
- Low NPSH applications [high suction lift pumps].
- Crude oil processing, drilling mud, waste chemicals, oil/water separation.

ATEX

ATEX is a European certification that aims to minimize and prevent any possible risk of explosion when equipment is used in potentially explosive atmosphere.

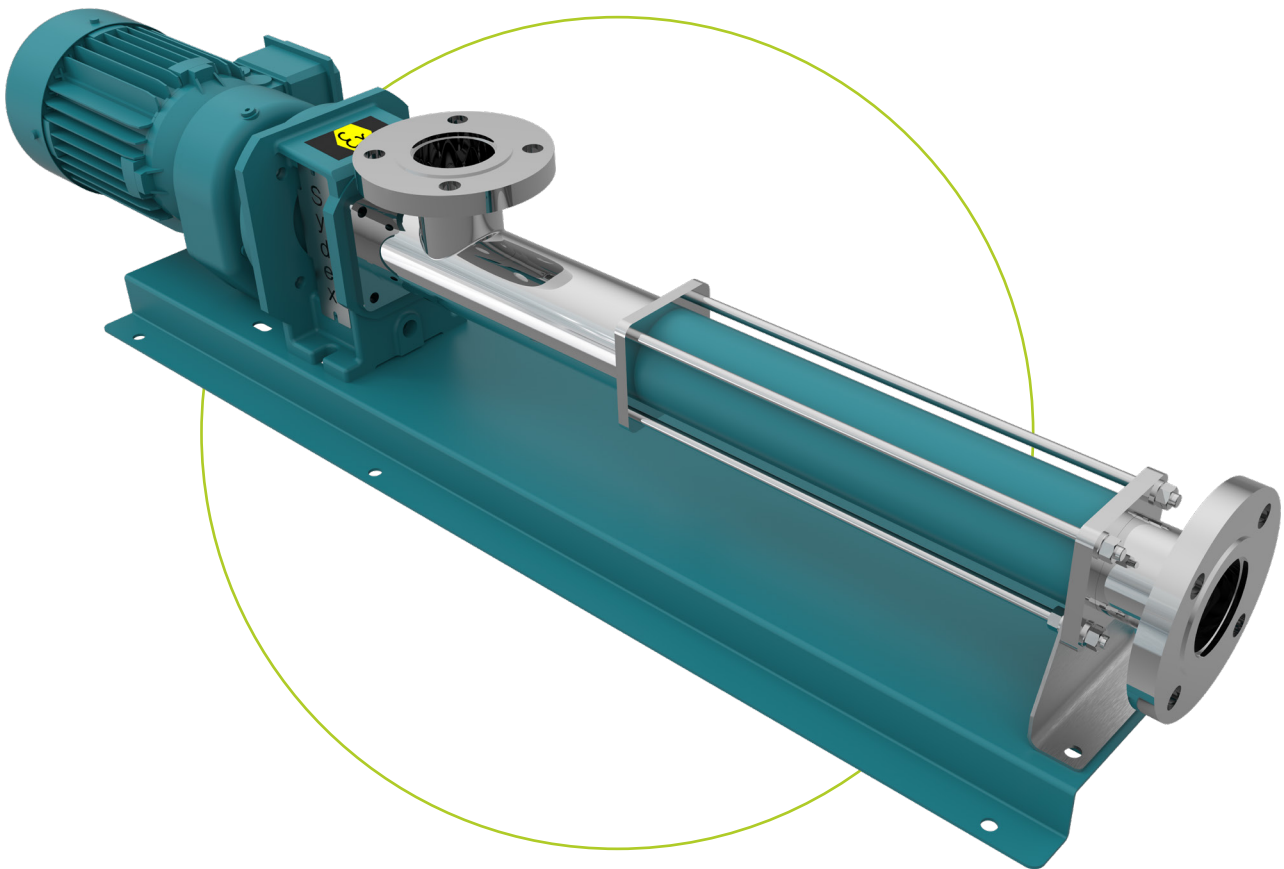

The ATEX rating is reported on the pump nameplate to identify the operating conditions and the protection level of the product:

CE ϵ x II 2 G Ex h IIB T4 Gb X
ATEX MARKING TYPE OF PROTECTION GAS GROUP MAX. SURFACE TEMPERATURE EPL



ATEX certification is required within the Industrial Pump Industry when the product is used in a potentially explosive environment.

Many substances and chemicals, such as flammable gases, mists or vapours or combustible dust, can cause an explosion when exposed to an ignition source.

Sydex pumps are ATEX certified and suit all the requirements of your operating conditions.

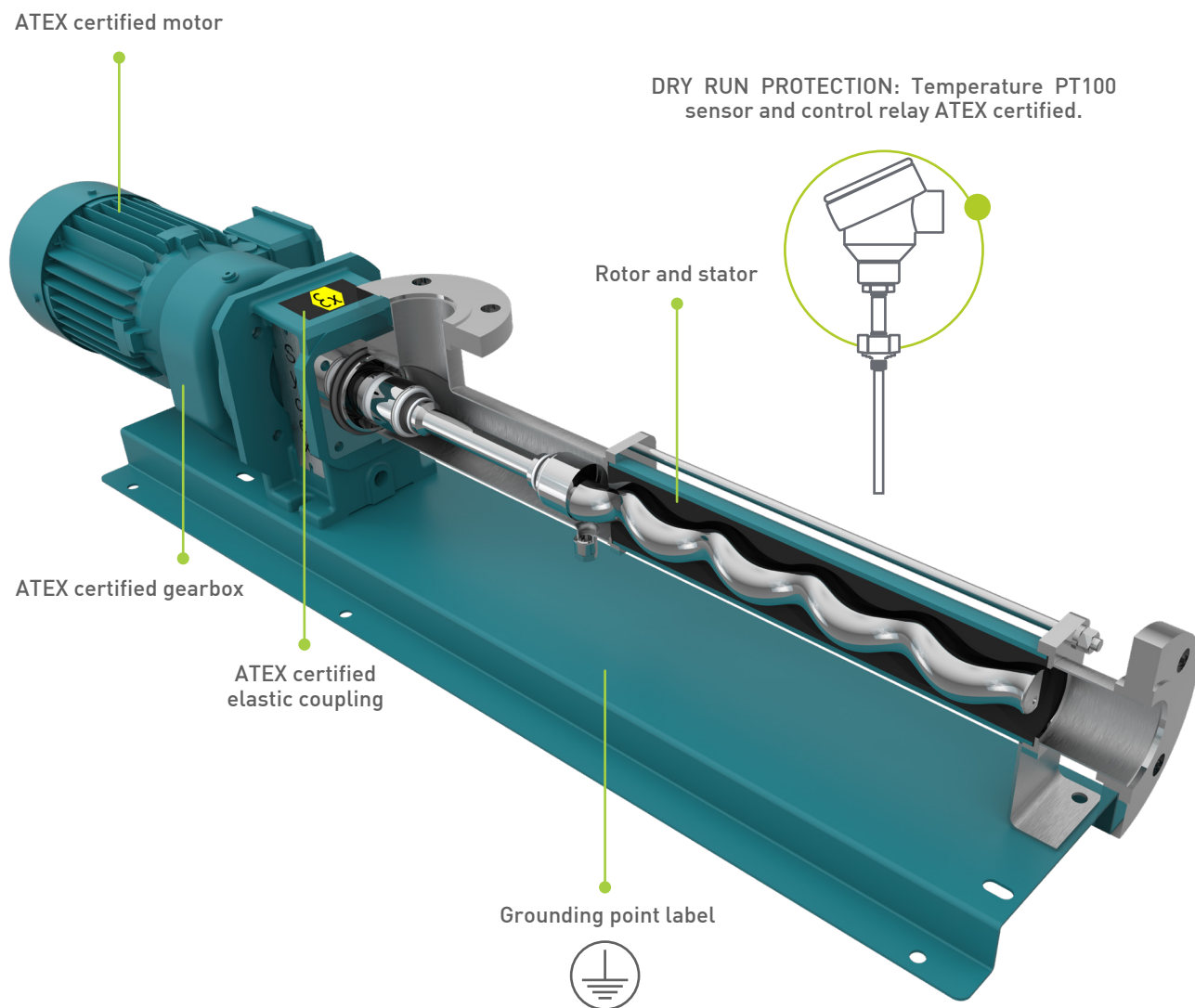

Product group II - Category group 2 Ambient: Gases, vapours
 Protection principle. Type of protection "C" : high level
 Explosion group
 Temperature class
 Equipment protection level (EPL): Gb

Defender

Industrial Grinder

The Sydex Defender grinder protects your pump from potential damages caused by downstream solids wastes.

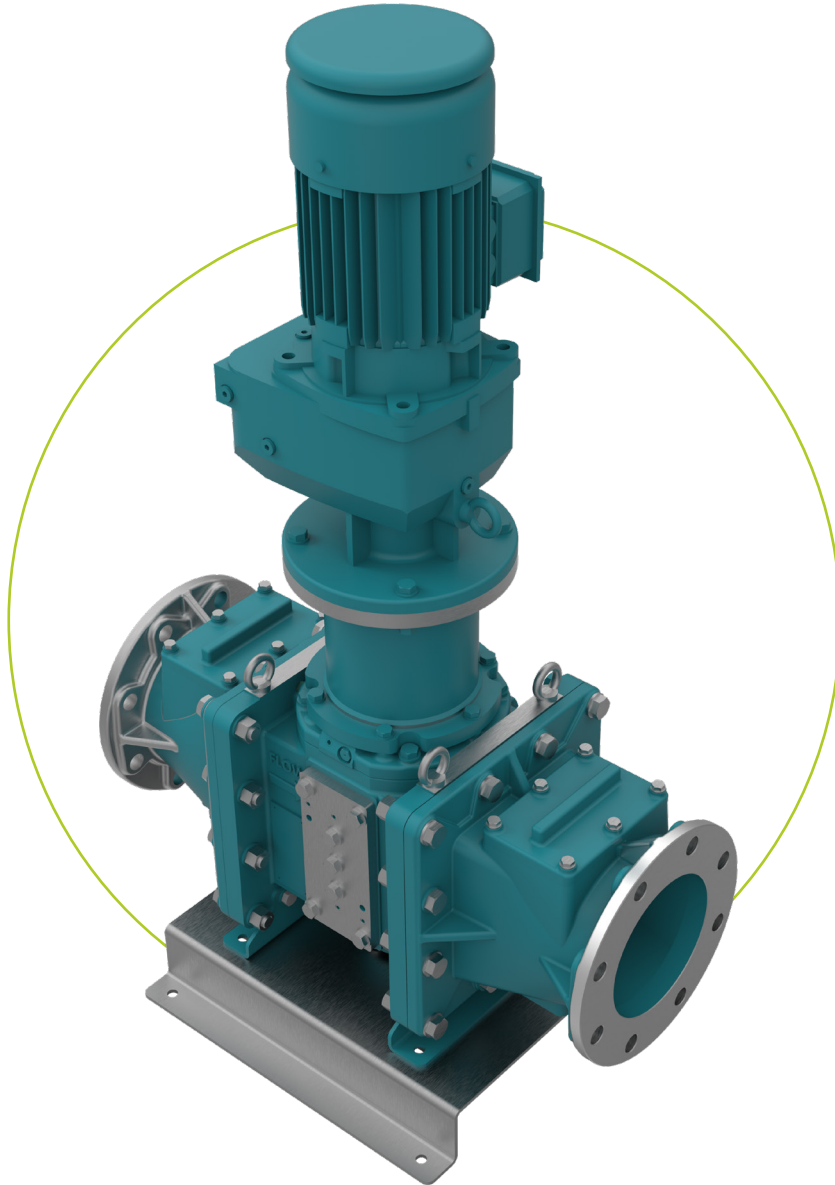

Advantages

- Robust design, clearest delivery time and best value for money in the market.
- Maximum reliability with low speed, high-torque gearbox.
- High quality and maximum efficiency of the cutting parts.
- Secured installation through the support feet with bolt-holes.
- Special hybrid mechanical seal with grease ring for long leak-free service life, combined with grease-lubricated double bearing arrangement.
- Wide range of connection fittings.

Maintaining effective flow and preventing damage to pumps is notoriously difficult when dealing with fluids with a high level of solids or suspended materials. Installing a Sydex Defender grinder on the inlet side allows reducing particles to a small manageable size and eliminating the risks of blockage, backflow premature wear and pump damage. As flow is not dependent on pressure, this provides an ideal solution when fitted to the pump suction pipework, therefore protecting your pumps and plant from the risk of damage and downtime.

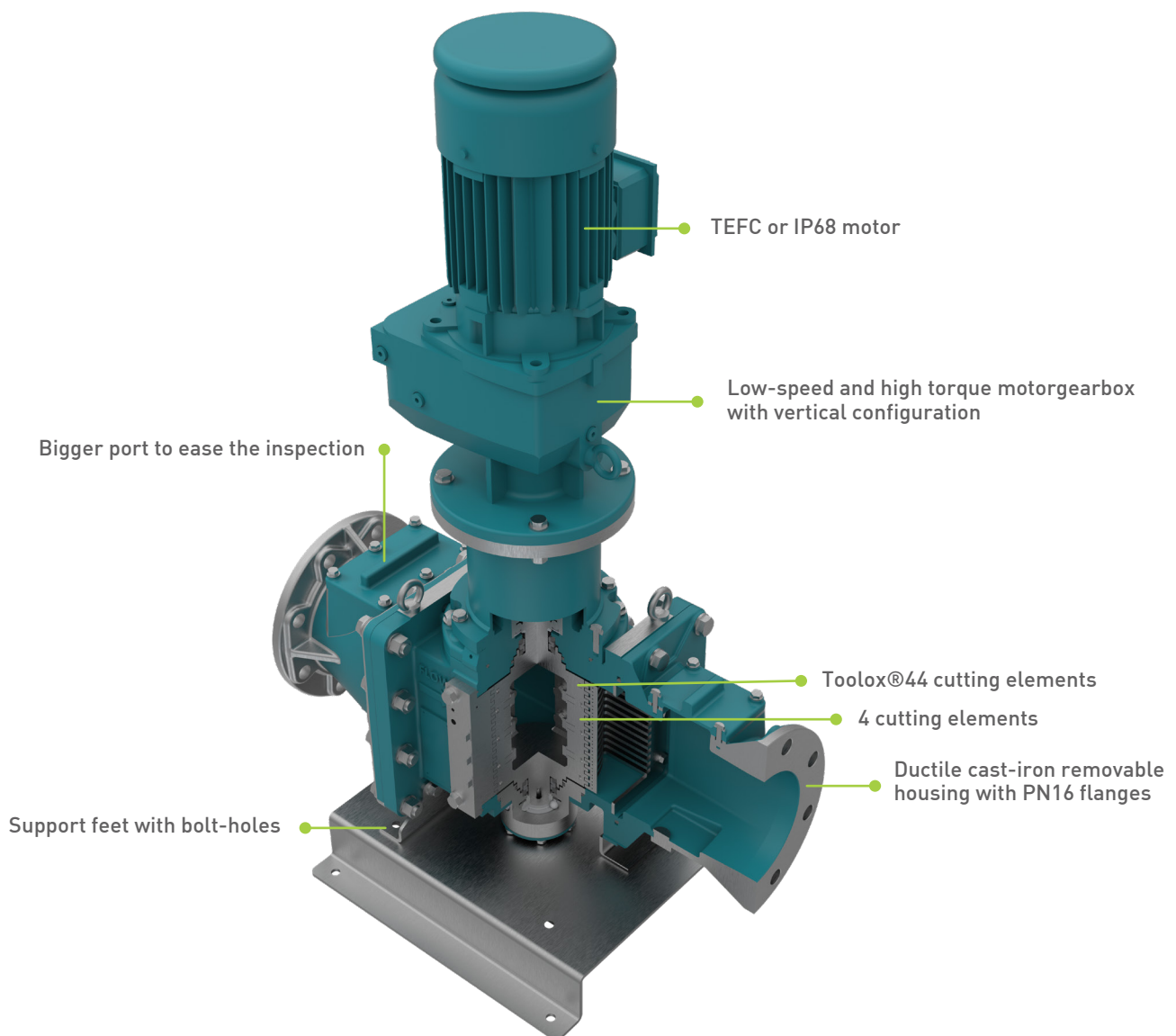

Application fields

- Industrial applications in environmental technology.
- Industrial applications in the oil & gas industry.
- Industrial applications for fluid with solids.

C031 Cutter

C031 Cutter Pumps

The Sydex C031 Cutter range is the combination of a progressing cavity pump and a macerator.

Maintaining effective flow through small bore pipes over longer distances or high lift is notoriously difficult when dealing with fluid with a high level of solids or suspended materials. As flow is not dependent on pressure, Sydex Eliminator C031 provides an ideal solution to many difficult demanding applications with a single compact package.

This self-priming progressing cavity macerator pump is capable of significant suction lift, making it ideal for many difficult applications. The hardened stainless steel cutter of the integral macerator unit cuts and shreds the solids into small particles before entering the pumping element. This efficiently macerated waste is then easily transferred to the final destination without risk of blockages or failure.

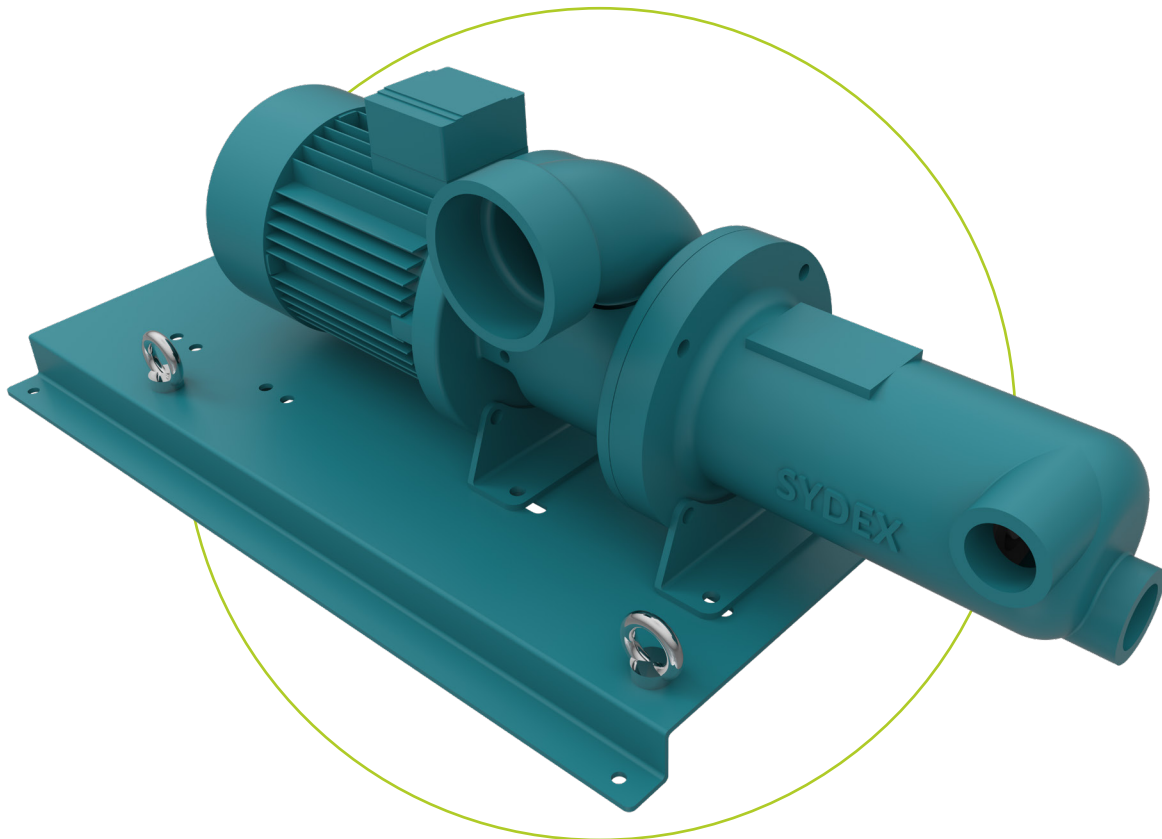

Advantages

- Robust design, clearest delivery time and best value for money in the market.
- Flexible ports (positioning 90°) providing flexible installation options.
- Two hardened stainless steel cuttings parts: bi-hammer action for effective breakdown and maceration of solids.
- Double bearing arrangement providing independent shaft support and offering better performance and reliability.
- Mechanical seal for a long leak-free service life.
- Stainless steel solid rotor.
- Easy of maintenance design of self-sealing and compact stator.

Ideal for domestic or small commercial premises where main sewerage or drainage is not available or where gravity feed is insufficient, the Eliminator can be an attractive and very cost effective solution. This macerator progressing cavity pump is also a good compromise to replace submersible pumps.

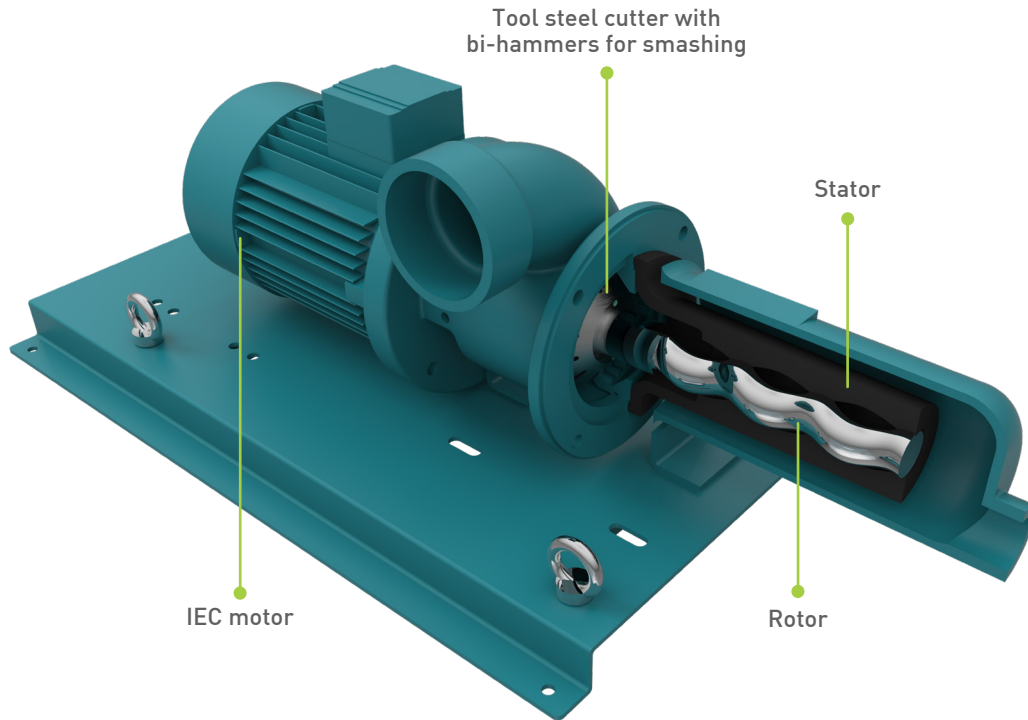

Configurations

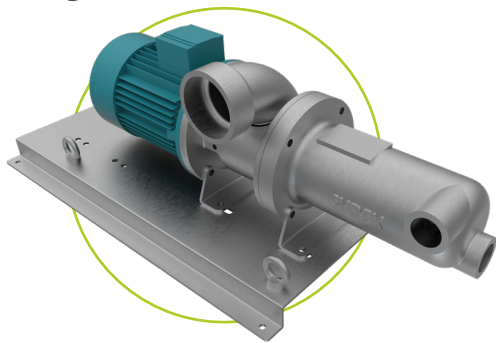

CF8M

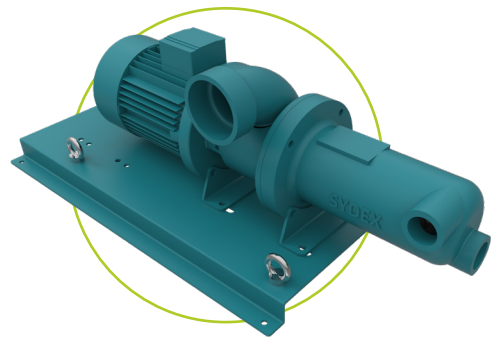

Cast-iron

Application fields

- Industrial applications in environmental technology.
- Industrial applications in the food industry.
- Industrial applications in the oil & gas industry.
- Industrial applications for fluid and viscous media with and without solids.

Sydex - A customer oriented company

As volumetric pumps manufacturer, Sydex designs, manufactures and markets progressing cavity pumps to transfer a multitude of Newtonian and non-Newtonian fluids, as well as grinders and conveyors. Sydex company was founded on the principles of quality management throughout all departments of the business, right through to total customer satisfaction, and the legendary reliability of our pumps.



Sydex is dedicated to providing the highest quality products and services that constantly meet or exceed customer expectations. The company's philosophy is that Quality assurance commences with the design of the product, and ends only when the customer obtains acceptable product function, perceived value and service. Sydex achieved TUV nord – ISO 9001:2015 quality certification in May 2007. In addition, our pumps can be provided with ATEX hazardous area certification by Eurofins.



Now with a true multinational organisation, the Sydex Group is continuing to represent technical excellence, quality, value and availability across the globe with:

-  SYDEX SRL in Italy - www.sydexpump.com
-  TORQUEFLOW SYDEX LTD in Great Britain - www.torqueflow-sydex.com
-  SYDEX SINGAPORE PTE LTD in Singapore - www.sydexpump.com
-  SYDEX FLOW in Portugal - www.sydexflow.com
-  SYDEX USA in United States of America - www.sydexpump.com

Lobe

Danmark
Fabriksvej 13-15
6580 Vamdrup

Norge
Billingstadsletta 25
1396 Billingstad

Sverige
Skeppsbrogatan 55
392 31 Kalmar