



SCREW CONVEYOR TECHNOLOGY

FOR BIOMASS AND BULK MATERIALS



OUR TECHNOLOGY MAKES AN IMPACT.



OUR TECHNOLOGY MAKES AN IMPACT.

We at Konrad Pumpe GmbH have made it our business to make a valuable contribution to sustainability in the biogas and recycling industry. To this end, we develop and produce high-quality dosing units for our customers worldwide.

As a family-run company since 1830, we are experienced in the development and manufacture of plants and machines for use in biogas and agricultural technology as well as in industry. Our special expertise lies in storage, processing and conveying technology for use in the biomass and recycling sector.

In order to meet the high quality demands of our customers, we primarily use stainless steel. In this way, we guarantee the highest operational safety with a long service life.

Our entrepreneurial thinking and actions are reflected in our products, which stand for progress, economic efficiency and durability. For this, we give our best every day - out of love for our work and for a better environment that we make more sustainable.

M. Pumpe *S. Pumpe*

Managing Director
Konrad Pumpe

Managing Director
Stefan Pumpe

THE STRENGTHS OF TECHNOLOGY

STRUCTURE AND CONVEYING CAPACITY

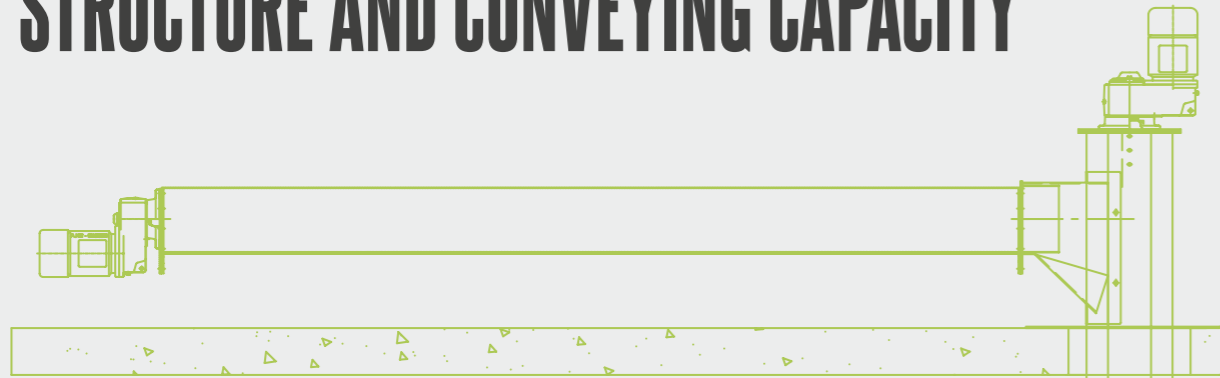

ADVANCED SCREW CONVEYOR TECHNOLOGY

Konrad Pumpe GmbH offers you customised, sustainable and low-wear screw conveyor technology in mechanical conveying. This is specially designed for the transfer of substrates that are difficult to convey, such as grass silage, solid manure or maize straw. In order to ensure maximum reliability with the best quality, the screw conveyors are manufactured with the utmost care and precision. The systems are made of stainless steel of various grades and are available in four different sizes: TYPE 360, TYPE 450, TYPE 550 and TYPE 600. You can obtain the screw conveyors in various designs and conveying capacities that meet the most diverse requirements in terms of conveying quantity and substrate composition. Whether as a partial solution for individual areas or as a complete solution for your entire process - we supply you with the right technology.

The fermenter screws are gas-tight and can also be pulled out for maintenance purposes without loss of gas.



TYPE 450

Drawing of a fermenter screw TYPE 360 top-loading according to ATEX



TYPE 450

TYPE 450

The TYPE 450 screw conveyor can be installed as a double-section screw conveyor for filling high fermenters.



TYPE 450

The three-part screw conveyor system TYPE 450 according to ATEX doses the substrate directly into the fermenter.



TYPE 360

The TYPE 360 and TYPE 450 steep-angle screw conveyors enable a double feed into two fermenters.



TYPE 360

The double horizontal screw conveyor TYPE 360 is a conveyor system for receiving substrates from push floor systems. In combination with a vertical screw conveyor and fermenter screw conveyor, direct intake is made possible here. In addition, our screw conveyors offer a solution in combination with other makes.



TYPE 360

With the three-part screw conveyor TYPE 360 (also TYPE 450), the vertical screw conveyor is the supporting element for the fermenter screw. This is guided freely through the silo connection plate and thus ensures decoupling between the screw conveyor technology and the fermenter wall. The horizontal screw conveyor is decoupled from the vertical screw conveyor to optimise weighing accuracy.



ENTRY OPTIONS SOLUTIONS FOR EVERY BUSINESS.

SOPHISTICATED SYSTEMS WITH HIGH-QUALITY EQUIPMENT

The horizontal and inclined screw conveyors are designed as trough screws, which are lined with wear-resistant bearing plastic. The special shape of the outer tube of the vertical screws inhibits the rotational movement of the substrate in the screw conveyor and thus ensures continuous conveying of even the most difficult materials. The advantage of vertical conveying is that the screw tree is centred in the substrate

being conveyed and has no contact with the outer casing. The screw drives are durable and robust flat-gear motors, which are designed in accordance with the applicable ATEX directives in the EX area. The easy-to-assemble system technology makes it possible to install the pre-assembled screw systems ready for operation in just a few hours.



Fermenter screws TYPE 600 according to ATEX feed the fermenter directly. Both units are equipped with a slide opening for this purpose.



The fermenter screw TYPE 600 with vertical entry according to ATEX feeds the fermenter directly. The solids feeder transfers the substrate into the fermenter screw via a hydraulic slide opening



The two-part screw conveyor system TYPE 360, consisting of a horizontal and fermenter screw in accordance with ATEX, feeds the substrate directly into the fermenter.



The TYP 450 screw conveyors can be connected to all common liquid feed systems with flexible transitions in order to feed them reliably and in a metered manner with solids.



Two independent feed systems feed two liquid feed systems. One of them feeds into a vertical shredder via a two-part TYPE 450 screw conveyor system with magnetic separator. It is then transported to an external liquid feed system by a TYPE 450 flex transfer. The other is equipped with a TYP 450 horizontal screw conveyor with flexible transfer that conveys into an external liquid feed system.



A two-part TYPE 450 screw conveyor system consisting of a horizontal and an inclined screw conveyor feeds a vertical shredder. The feed rate is individually adapted to the performance level of the downstream vertical shredder and the desired degree of shredding.



A two-part screw conveyor system consisting of a TYPE 450 horizontal and an inclined screw conveyor with magnetic separator transfers the substrate to a vertical shredder.



A feed system with two connected TYPE 450 screw conveyors simultaneously feeds two external liquid feed systems.

WALL DUCT



SILO CONNECTION PLATE FOR FERMENTER SCREWS

The silo connection plate is sealed against the fermenter wall and can also be retrofitted to existing systems. The feedthrough pipe is immersed in the liquid substrate in the fermenter until below the minimum fill level, thus ensuring that no gas can escape even when the fermenter screw is dismantled. The special feature of the system is that the fermenter screw can be dismantled even when the fermenter is full. Lowering the filling level is not necessary.



FERMENTER SCREW

Due to a special bearing integrated in the housing of the fermenter screw, no end bearing is required. The material to be conveyed is fed freely to the fermenter. This measure reduces wear.

TECHNICAL DATA DETAILS AT A GLANCE.



SCREW CONVEYOR KIT TYPE 360 / 450 / 550

- 1 Vertical screw conveyor and fermenter screw conveyor with drive according to ATEX
- 2 Vertical screw conveyor made of stainless steel V2A (AISI 304). This is also suitable for high fermenters.
- 3 Solids dosing unit
- 4 Sub-screw made of stainless steel V2A (AISI 304)
- 5 Wall feed-through made of stainless steel V4A (AISI 316Ti) 35° or 45°
- 6 Fermenter screw conveyor made of stainless steel V4A (AISI 316Ti) in design according to ATEX316Ti)
- 7 Rotatable flange

The 3-part screw conveyor is capable of taking up and dosing different substrates. The vertical screw conveyor takes on a supporting function for the fermenter screw conveyor. The vertical screw and the fermenter screw can be flexibly adapted to the installation situation of the fermenter by means of a rotatable flange. A wall feed-through is installed to seal off liquids and gases in concrete fermenters.



FERMENTATION SCREW CONVEYOR TYPE 600 VERTICAL

- 1 Screw conveyor with drive according to ATEX
- 2 Overall construction in stainless steel V4A (AISI 316Ti)
- 3 Mounting plate for the digester ceiling
- 4 Conveyor shaft made of stainless steel V4A (AISI 316Ti)

With this system, the solids feeder must be equipped with a hydraulic slide opening. This allows the material to be fed from the solids feeder into the fermenter screw without contact. The feed rate is determined by the size of the slide opening.



FERMENTER SCREW TYPE 600 WITH SIDE ENTRY

- 1 Screw conveyor with drive according to ATEX
- 2 Overall construction made of stainless steel V4A (AISI 316Ti)
- 3 Mounting plate for gas-tight attachment to the fermenter wall.

With this set-up, the solids feeder must be equipped with a hydraulic discharge gate. A transfer chute conveys the substrate from the solids feeder into the digester screw.

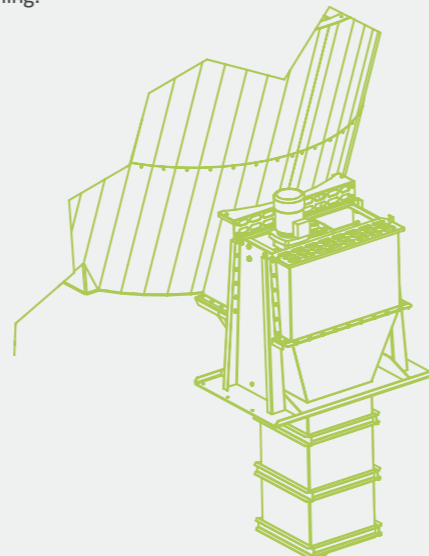

TYPE	Capacity up to m³/h	Ø Screw flight	Material thickness	Overall length (m)	Drive power (kW)	Overall length (m)	Drive power (kW)	Material V2A (AISI 304)	Gas section V4A (AISI 316Ti)	Bore hole fermenter wall
Inferior screw conveyor TYPE 360	12	250	8	<5,50	3	<8,50	4	x		
Steep screw conveyor TYPE 360	12	280	8	<7,20	5	<9,00	6,8	x		
Fermenter screw conveyor TYPE 360	12	250	8	<3,50	2,5			x	x	450
Inferior screw conveyor TYPE 450	22	360	8	<4,50	4	<6,00	5,5	x		
Steep screw conveyor TYPE 450	22	360	8	<4,50	5	<8,00	6,8	x		
Fermenter screw conveyor TYPE 450	22	360	8	<3,50	3,6			x	x	550
Inferior screw conveyor TYPE 550	22	460	10	<6	2,2			x		
Steep screw conveyor TYPE 550	22	460	10	<8	5,5			x		
Fermenter screw conveyor TYPE 550	22	460	10	<4	4			x	x	700
Fermenter screw conveyor TYPE 600/90°	20	450	8	<3,50	3,6			x	x	700
Fermenter screw conveyor TYPE 600/55°	20	450	8	<3,50	3,6			x	x	700

FULL-SERVICE FOR YOUR SUCCESS.

WE ARE THERE FOR YOU!

Even after commissioning, we are your professional partner who supports the operational readiness of your system in the long term. For this purpose, we have developed a comprehensive full service that offers you professional competence, fast availability and high readiness as well as flexibility for every request. In this way, we guarantee the economic success of your operation.



SUPPORT

From design and production to assembly and maintenance - our trained staff is there to advise and support you in every situation.



CUSTOMISATION

We create customised solutions for every system. Taking into account the local conditions, our designers work out a customised, economical and durable concept.



PROFESSIONAL ASSEMBLY

Our expert fitters are on site on the delivery date and take over the installation and commissioning of your screw conveyor technology. They will then train your personnel in the operation of the system.



MAINTENANCE WORK

To ensure the longevity of your screw conveyor technology, we recommend that you have your system serviced by our fitters at regular intervals.



SPARE PARTS IN STOCK

Due to our high vertical range of manufacture, spare parts, wear parts and even special components can be supplied at short notice.



EMERGENCY SERVICE

In case of an emergency, you can also reach us outside business hours, 365 days a year. You can find the duty times of our emergency service at: www.pumpegbh.de/en/emergency-service



Secure an efficient and long-lasting system for the transfer of your substrates with screw conveyor technology!

YOUR ADVANTAGES

- ✓ Quality-tested and proven construction "Made in Germany"
- ✓ Made to measure production
- ✓ Reliable conveying of the most demanding substrates
- ✓ Trouble-free material flow
- ✓ Low wear and energy consumption costs
- ✓ Can be implemented as a complete or partial solution
- ✓ Compatible with downstream injection systems
- ✓ Can be designed in accordance with the applicable ATEX directives
- ✓ Full-Service

ARE YOU INTERESTED IN SCREW CONVEYOR TECHNOLOGY?

Contact our sales team:

E-MAIL: sales@pumpegbh.de
 FON: +49 (0) 2526 / 9329-0
 FAX: +49 (0) 2526 / 9329-25

Konrad Pumpe GmbH

Schörmelweg 24
 D-48324 Sendenhorst
www.pumpegbh.de/en



KONRAD PUMPE GMBH

www.pumpegbh.de/en



SCAN
to our
website!

THE SPECIALIST COMPANY FOR PLANT

Founded in 1830 as a blacksmith's shop, we at Konrad Pumpe GmbH are now an innovative specialist company for mechanical and plant engineering with approx. 80 employees. We have made it our business to make a valuable contribution to the sustainable handling of waste materials. To this end, we

produce customised machine components for a wide range of applications such as dosing and conveying systems, including switch cabinet and control system construction for biogas and recycling plants.

BIOGAS TECHNOLOGY



We produce high-quality and robust dosing systems for the biogas and recycling sector, which are designed for different uses. Our proven product range impresses with high quality, durability and energy-efficient use in the processing of demanding substrates.

DOSING TECHNOLOGY



For the agricultural sector, we build dosing technology and mixing containers for different feedstuffs. Our machines are suitable for various fields of application and are characterised by their functionality and flexibility, which meet the highest demands for quality, performance and durability.

MECHANICAL ENGINEERING

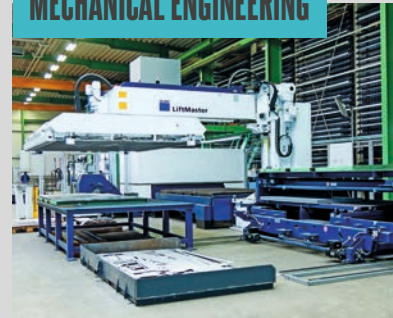

State-of-the-art CNC and laser technology is part of the basic equipment of our in-house machinery. Here, we produce customised products and our own developments for a wide range of applications in the agricultural and industrial sectors. Steel and stainless steel are the main materials processed.

Errors and changes excepted

