

THE MULTICRUSHER  
OCEAN



# ROBUST AND RELIABLE

## THE BÖRGER MULTICRUSHER OCEAN



Highest level of safety due to automatic switchoff

*According to the revised Annex V of the MARPOL convention, food waste from ships or offshore platforms may only be discharged into the sea in certain maritime areas if the waste is no larger than 25 mm.*

*In order to avoid the high costs of the storage of food and kitchen wastes for the shipping companies and to meet the requirements regarding the cutting result, Börger GmbH has developed the Multicrusher Ocean.*

The Multicrusher Ocean is a macerating unit with a powerful intake function. Blades are mounted on the shafts of the dual-shaft grinder. The solids to be macerated have to pass the blades rotating against each other.

The different circumferential speeds of the carrier shafts create an excellent cutting result.

The Multicrusher Ocean is very compact with minimum space requirements. So, it is perfect for use on the high seas.

### CONSTRUCTION

- 1 Control technology**  
*The multicrusher is operated by the operating device of the control unit. Several safety systems ensure that the macerator operates safely.*
- 2 Filling hopper**  
*At the top opening, the kitchen waste is fed through a hopper.*
- 3 Operating lever, „tamper“**  
*The "tamper" is used to feed the solids to be macerated completely.*
- 4 Multicrusher**  
*The two rotating blade blocks of the Multicrusher Ocean macerate the kitchen waste very efficiently < 25 mm.*
- 5 Auffangbehälter**  
*A container is placed below the macerator to collect the kitchen waste that has been macerated. You can easily remove the container.*

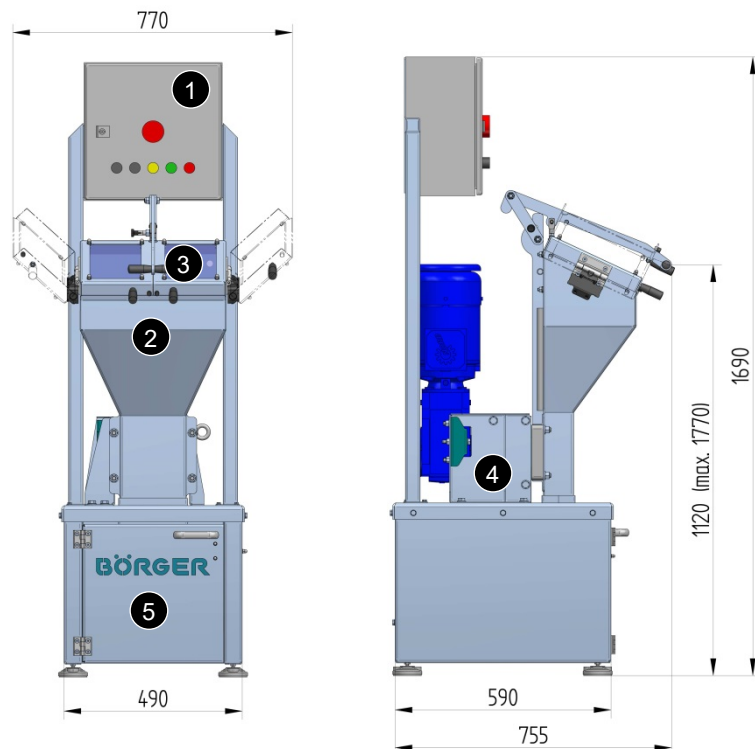

## AT A GLANCE

- + Made of stainless steel
- + Low-on space, compact design
- + Excellent cutting result (< 25 mm)
- + Discharge of kitchen waste into the sea possible
- + Ease of maintenance thanks to MIP (Maintenance in Place)
- + Easy and safe to operate
- + Reliable, powerful, robust

## BLADES

Various blade geometries ensure an excellent cutting result:



## EFFICIENT AND USER FRIENDLY

*Efficient dual-shaft grinder*

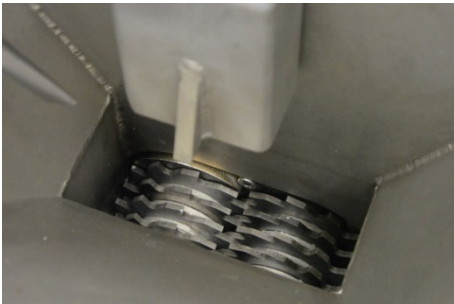

*Highest level of user friendliness*



## EXCELLENT CUTTING RESULT

*Kitchen waste before it has been macerated*



*Kitchen waste after it has been macerated*  
→ Result makes discharge into the sea possible



# BÖRGER®

EXCELLENCE – MADE TO LAST



**Börger GmbH**  
Borken-Weseke, Germany  
Phone +49 2862 9103-0  
[info@boerger.de](mailto:info@boerger.de)

**Börger Benelux**  
Ootmarsum, Netherlands  
[info@boerger-pumps.nl](mailto:info@boerger-pumps.nl)

**Boerger LLC**  
Chanhassen, MN, USA  
[america@boerger.com](mailto:america@boerger.com)

**Börger France Sarl**  
Wittersheim, France  
[info@borger.fr](mailto:info@borger.fr)

**Boerger Polska Sp. z o.o.**  
Gliwice, Poland  
[info@boerger.pl](mailto:info@boerger.pl)

**Börger UK Ltd.**  
Staffordshire, United Kingdom  
[uk@boerger.com](mailto:uk@boerger.com)

**Boerger Pumps Asia Pte Ltd**  
Singapore  
[asia@boerger.com](mailto:asia@boerger.com)

**Boerger Pumps Asia Pte Ltd**  
Gurugram, Haryana, India  
[india@boerger.com](mailto:india@boerger.com)

**Boerger Pumps (Shanghai) Co., Ltd.**  
Pudong, Shanghai, China  
[shanghai@boerger.com](mailto:shanghai@boerger.com)

**000 Börger Pumps**  
Moscow, Russia  
[russia@boerger.com](mailto:russia@boerger.com)

[www.boerger.com](http://www.boerger.com)